



Experimental Wave Tank Test for Reference Model 3 Floating- Point Absorber Wave Energy Converter Project

Y.-H. Yu, M. Lawson, and Y. Li
National Renewable Energy Laboratory

M. Previsic and J. Epler
Re Vision Consulting

J. Lou
Oregon State University

**NREL is a national laboratory of the U.S. Department of Energy
Office of Energy Efficiency & Renewable Energy
Operated by the Alliance for Sustainable Energy, LLC**

This report is available at no cost from the National Renewable Energy
Laboratory (NREL) at www.nrel.gov/publications.

Technical Report
NREL/TP-5000-62951
January 2015

Contract No. DE-AC36-08GO28308

Experimental Wave Tank Test for Reference Model 3 Floating-Point Absorber Wave Energy Converter Project

Y.-H. Yu, M. Lawson, and Y. Li
National Renewable Energy Laboratory

M. Previsic and J. Epler
Re Vision Consulting

J. Lou
Oregon State University

Prepared under Task No. WA14.1A01

**NREL is a national laboratory of the U.S. Department of Energy
Office of Energy Efficiency & Renewable Energy
Operated by the Alliance for Sustainable Energy, LLC**

This report is available at no cost from the National Renewable Energy Laboratory (NREL) at www.nrel.gov/publications.

NOTICE

This report was prepared as an account of work sponsored by an agency of the United States government. Neither the United States government nor any agency thereof, nor any of their employees, makes any warranty, express or implied, or assumes any legal liability or responsibility for the accuracy, completeness, or usefulness of any information, apparatus, product, or process disclosed, or represents that its use would not infringe privately owned rights. Reference herein to any specific commercial product, process, or service by trade name, trademark, manufacturer, or otherwise does not necessarily constitute or imply its endorsement, recommendation, or favoring by the United States government or any agency thereof. The views and opinions of authors expressed herein do not necessarily state or reflect those of the United States government or any agency thereof.

This report is available at no cost from the National Renewable Energy Laboratory (NREL) at www.nrel.gov/publications.

Available electronically at <http://www.osti.gov/scitech>

Available for a processing fee to U.S. Department of Energy and its contractors, in paper, from:

U.S. Department of Energy
Office of Scientific and Technical Information
P.O. Box 62
Oak Ridge, TN 37831-0062
phone: 865.576.8401
fax: 865.576.5728
email: <mailto:reports@adonis.osti.gov>

Available for sale to the public, in paper, from:

U.S. Department of Commerce
National Technical Information Service
5285 Port Royal Road
Springfield, VA 22161
phone: 800.553.6847
fax: 703.605.6900
email: orders@ntis.fedworld.gov
online ordering: <http://www.ntis.gov/help/ordermethods.aspx>

Cover Photos: (left to right) photo by Pat Corkery, NREL 16416, photo from SunEdison, NREL 17423, photo by Pat Corkery, NREL 16560, photo by Dennis Schroeder, NREL 17613, photo by Dean Armstrong, NREL 17436, photo by Pat Corkery, NREL 17721.

Acknowledgments

This work was supported by the U.S. Department of Energy under Contract No. DE-AC36-08-GO28308 with the National Renewable Energy Laboratory and Contract No. DE-AC04-94-AL85000 with Re Vision Consulting, LLC, through a subcontract with Sandia National Laboratories. Funding for this work was provided by the DOE Office of Energy Efficiency and Renewable Energy, Wind and Water Power Technologies Office.

List of Acronyms

FPA	floating-point absorber
PTO	power take-off
RAO	response amplitude operator
RM	reference model
WEC	wave energy converter

Executive Summary

The U.S. Department of Energy established a reference model (RM) project to benchmark a set of marine and hydrokinetic technologies including current (tidal, open-ocean, and river) turbines and wave energy converters. The objectives of the project were to 1) evaluate the status of these technologies and their readiness for commercial applications, and 2) assess the potential cost of energy and identify cost-reduction pathways and areas where additional research could be best applied to accelerate technology development to market readiness.

This report is an addendum to *SAND2013-9040: Methodology for Design and Economic Analysis of Marine Energy Conversion (MEC) Technologies* and describes the experimental wave tank tests conducted during the RM3 floating-point absorber (FPA) wave energy converter study. In the RM3 project, three sets of experimental wave tank tests were conducted to study FPA wave energy converter systems during both operational and extreme sea states. The specifications are listed in Table ES-1. The first set of wave tank tests focused on a locked FPA, which did not include a power take-off system, and analyzed the hydrodynamics of an FPA during extreme wave (survival) conditions. The second and third sets of tests evaluated the FPA power output during operational wave environments. The objective of this report is to provide experimental data sets for validating numerical simulation studies of wave tank tests. The wave tank test settings, model dimensions and properties, and post-processed data sets—including the measured wave environment, hydrodynamic response, and the estimated power output—are documented.

Table ES-1. Specifications of the Wave Tank Tests

Test Number	Type	Model Scale	Date	Wave Tank	Note
1	Locked-point absorber	1/100	10/2010	University of California at Berkeley	Tested a locked FPA system (no power take-off); focused on extreme waves
2	Heave-only power performance	1/33	8/2011	University of California at San Diego	Tested the power performance of a two-body heave-only FPA system
3	Mooring-connected power performance	1/33	11/2011	University of California at San Diego	Tested the power performance of a two-body FPA system with a larger diameter float and mooring connections

Table of Contents

1	Introduction	1
2	Test #1: Locked FPA Wave Tank Test	2
2.1	Tank Test Setup.....	2
2.2	Wave Tank Test Results.....	5
3	Test #2: Heave-Only FPA Power Performance Test	8
3.1	Tank Test Setup.....	8
3.2	Wave Tank Test Results.....	9
4	Test #3: Moored FPA Power Performance Test	12
4.1	Tank Test Setup.....	12
4.2	Wave Tank Test Results.....	14
5	Summary	17
	References	18

List of Figures

Figure 1. Schematic of the wave tank at the University of California at Berkeley.....	2
Figure 2. Locked FPA wave tank test and instrumentation setup. <i>Photo by Ye Li, NREL 20118</i>	2
Figure 3. Mooring line configuration (clockwise from top): side view, top view, and snapshot. <i>Photo by Ye Li, NREL 20117</i>	3
Figure 4. Schematic of the locked FPA model	4
Figure 5. Decay test time histories for the heave (top) and pitch (bottom) responses at full scale (scaled by the initial displacement and rotational angle)	6
Figure 6. Heave (top), surge (middle), and pitch (bottom) RAOs for the locked FPA (scaled by the wave height)	7
Figure 7. Schematic of the wave tank at the Scripps Institution of Oceanography at the University of California at San Diego.....	8
Figure 8. Heave-only FPA wave tank test. <i>Photos by Yi-Hsiang Yu, NREL</i>	8
Figure 9. Schematic of the heave-only FPA testing model (model scale)	9
Figure 10. Relative heave RAO for the heave-only FPA at full scale	11
Figure 11. Power output for the heave-only FPA at full scale.....	11
Figure 12. Moored FPA power performance test setup. <i>Photos (clockwise from left) by Mike Lawson, Mike Lawson, and Yi-Hsiang Yu</i>	12
Figure 13. Schematic of the two-body FPA (in inches).....	13
Figure 14. PTO design: (a) configuration schematic, (b) hydraulic piston, and (c) orifice design inside the piston. <i>Illustrations from Previsic, Shoele, and Epler 2014</i>	14
Figure 15. Relative heave RAO of the model at full scale.....	16
Figure 16. Power output of the model at full scale	16

List of Tables

Table ES-1. Specifications of the Wave Tank Tests.....	v
Table 1. Specifications of the Wave Tank Tests.....	1
Table 2. Mooring Line Configuration (Model Scale).....	3
Table 3. Properties of the FPA Model (Model Scale).....	4
Table 4. Matrix for the Locked FPA Tank Test (Full Scale).....	5
Table 5. Mass Properties for the Heave-Only Testing Model (Model Scale).....	9
Table 6. Matrix for the Heave-Only FPA Power Performance Tank Test (Full Scale).....	10
Table 7. Mooring Line Configuration (Model Scale).....	12
Table 8. Mass Properties for the Moored Testing Model (Model Scale).....	13
Table 9. Matrix for the Moored FPA Power Performance Tank Test (Full Scale).....	15

1 Introduction

The U.S. Department of Energy established a reference model (RM) project to benchmark a set of marine and hydrokinetic technologies including current (tidal, open-ocean, and river) turbines and wave energy converters (WECs). The project's objectives were to 1) evaluate the status of these technologies and their readiness for commercial applications, and 2) assess the potential cost of energy and identify cost-reduction pathways and areas where additional research could be best applied to accelerate technology development to market readiness.

In the RM3 floating-point absorber (FPA) project, a series of experimental wave tank tests was performed to understand the hydrodynamic and power performance of FPA wave energy converter systems. Researchers from the National Renewable Energy Laboratory and Re Vision Consulting performed three sets of experimental wave tank tests (the specifications are shown in Table 1). The first set tested a locked FPA (no relative motion of the two main bodies), which did not include a power take-off (PTO) system, and analyzed the hydrodynamics of an FPA during extreme wave (survival) conditions. The second and third sets of the wave tank tests evaluated the FPA power output during operational wave environments.

Table 1. Specifications of the Wave Tank Tests

Test Number	Type	Model Scale	Date	Wave Tank	Note
1	Locked-point absorber	1/100	10/2010	University of California at Berkeley	Tested a locked FPA system (no PTO); focused on extreme waves
2	Heave-only power performance	1/33	8/2011	University of California at San Diego	Tested the power performance of a two-body heave-only FPA system
3	Mooring-connected power performance	1/33	11/2011	University of California at San Diego	Tested the power performance of a two-body FPA system with a larger diameter float and mooring connections

The model designs and levelized cost of energy estimations for the RM3 project were described in *Methodology for Design and Economic Analysis of Marine Energy Conversion (MEC) Technologies* (Neary et al. 2014). The objective of this report is to provide experimental data sets that can be useful for validating numerical simulation studies. Preliminary use of this data was presented in Previsic, Shoele, and Epler 2014; Ruehl et al. 2014; Yu et al. 2014a and 2014b; and Yu and Li 2013. The following sections of this report present the wave tank and test article setup and measured results for each set of the experimental tests. For consistency, all results are presented in full scale, except for the model dimensions and properties and test settings.

2 Test #1: Locked FPA Wave Tank Test

The locked FPA wave tank test was conducted at the University of California at Berkeley in December 2010. The test focused on extreme wave condition analysis. Because the FPA system generally has a survival mode that locks the float to the central column during an extreme wave environment, we designed the testing model as a single rigid body without a PTO representation. This section presents the tank test setup and the measured testing model response.

2.1 Tank Test Setup

The dimensions of the wave tank at the University of California at Berkeley are plotted in Figure 1, and the experimental setup is shown in Figure 2.

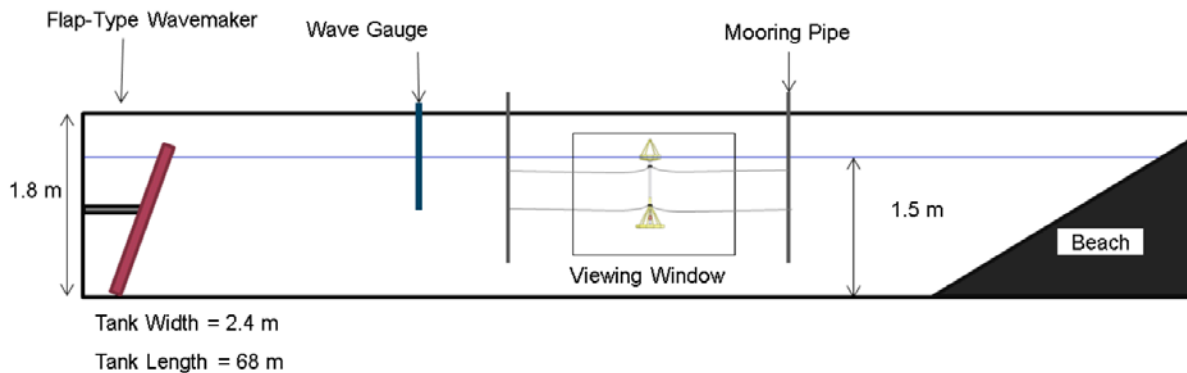

Figure 1. Schematic of the wave tank at the University of California at Berkeley

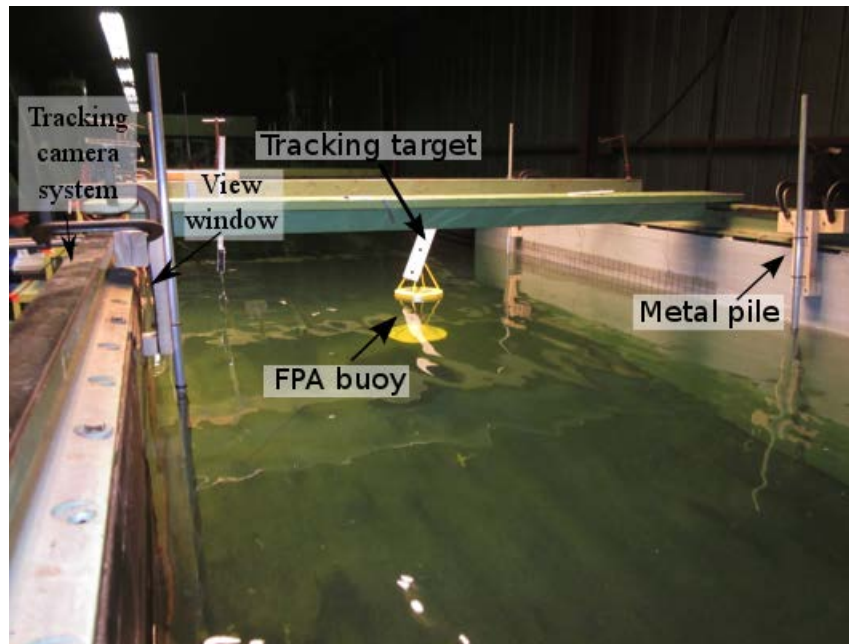

Figure 2. Locked FPA wave tank test and instrumentation setup. Photo by Ye Li, NREL 20118

The wave tank was designed to test ships and large offshore structures but was not intended to test moored floating systems, therefore four metal piles were installed on the tank's sidewalls (two piles on each side) to attach the mooring lines. As shown in Figure 3, the FPA device was connected to eight mooring lines, and each mooring line was connected to a metal pile on the sidewall. These eight lines were located in two layers, and each layer had four lines in the configuration of a cross. The properties of the mooring settings are given in Table 2.

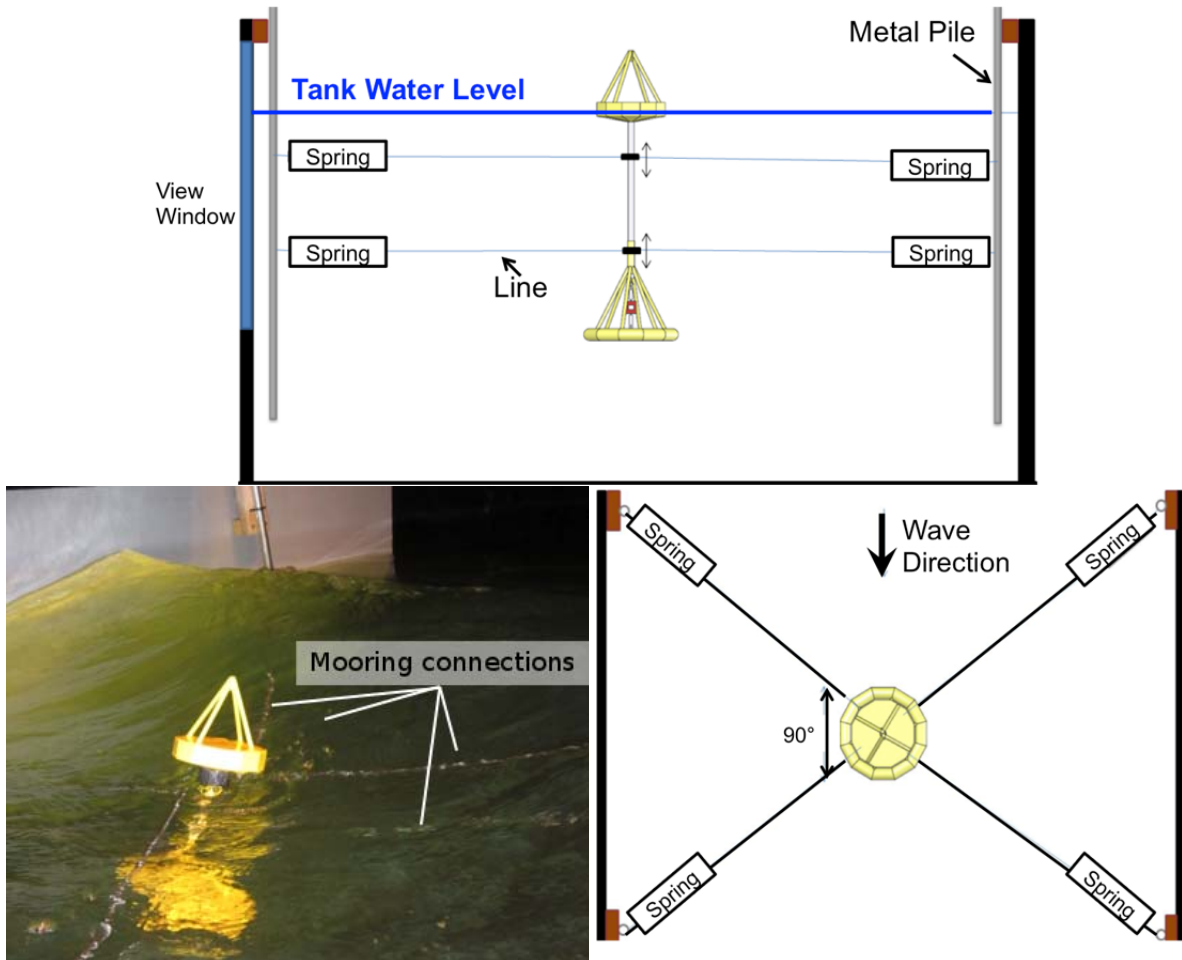

Figure 3. Mooring line configuration (clockwise from top): side view, top view, and snapshot. Photo by Ye Li, NREL 20117

Table 2. Mooring Line Configuration (Model Scale)

Mooring Settings	1/100-Scale Model
Top layer connection	0.05 meters (m) below mean free surface
Bottom layer connection	0.10 m above the damping plate
Spring stiffness	≈ 0.7 Newton (N)/m (each line)

To test the system during extreme wave conditions (large wave height scenarios), the test was conducted using a 1/100-scale model because of the tank’s limited wave-making capability. Figure 4 shows the geometry and dimensions of the testing model, and its mass properties are listed in Table 3. Note that the mass of the models listed in the table includes the mass of the device and the target plate for the motion tracking system.

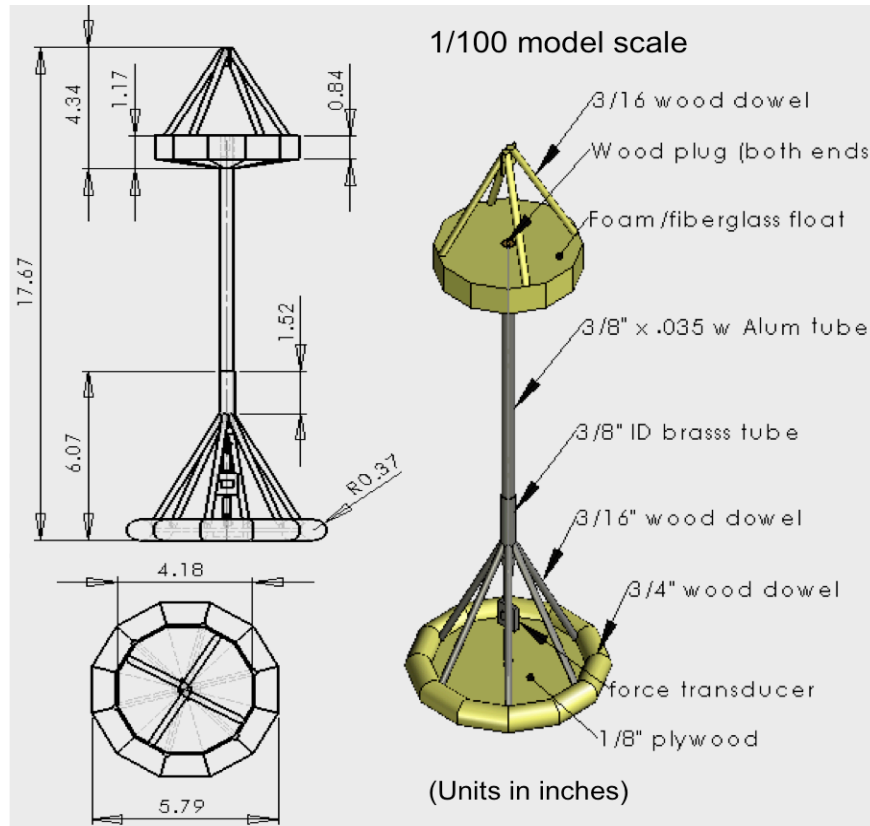

Figure 4. Schematic of the locked FPA model

Table 3. Properties of the FPA Model (Model Scale)

Model Properties	1/100-Scale Model
Center of gravity	0.23 m below mean free surface
Moment of inertia for pitch	7.22 grams (g)*m ²
Mass	313 g

Researchers placed an analog wave gauge 5.2 meters (m) upstream of the FPA to measure the incoming wave height. Next, we attached a plate with passive markers (that could be targeted by the motion-tracking system) to the buoy, whereas the surge, heave, and pitch motions were captured by the two-dimensional motion-tracking system, which was installed next to the wave tank.

2.2 Wave Tank Test Results

Table 4 provides the test cases for the locked FPA wave tank trials, including heave and pitch decay tests (no mooring and no incoming wave) and regular wave tests, where the model was connected to the mooring system. The testing model root-mean-square (RMS) response values in heave, surge, and pitch at the center of gravity and the measured wave heights and wave periods are also listed in Table 4. Although the tank test focused on extreme wave conditions (design wave heights of 9 m and 15 m at full scale), wave tank tests with a wave height of about 3 m (full scale) were also conducted for reference purposes.

Table 4. Matrix for the Locked FPA Tank Test (Full Scale)

Decay Test					
Heave decay		Initial displacement was 2 m			
Pitch decay		Initial pitch angle was 5.7 degrees			
Regular Waves					
Test Number	Measured Wave Height Meters (m)	Measured Wave Period Seconds (s)	Measured RMS Surge (m)	Measured RMS Heave (m)	Measured RMS Pitch Radian (rad)
1	3.07	17.52	2.81	3.44	0.14
2	3.21	15.02	2.72	3.43	0.14
3	3.24	12.42	2.51	4.23	0.10
4	3.11	10.18	1.13	4.10	0.04
5	3.02	9.38	1.05	3.72	0.06
6	3.04	8.70	1.43	2.87	0.07
7	3.01	7.50	1.51	2.26	0.08
8	9.37	17.58	8.50	11.09	0.26
9	9.74	14.88	7.18	10.56	0.22
10	9.73	12.46	4.74	8.53	0.08
11	9.61	11.22	3.07	5.68	0.11
12	8.75	10.18	2.86	4.48	0.14
13	9.16	9.53	3.30	3.67	0.16
14	8.92	8.86	3.68	3.15	0.16
15	15.67	17.58	13.82	14.96	0.27
16	15.52	14.76	12.02	11.49	0.18
17	15.47	12.53	7.32	8.96	0.11
18	15.17	11.12	5.72	6.34	0.10
19	14.63	10.25	5.06	4.98	0.11
20	13.97	9.47	4.24	3.94	0.12
21	13.32	8.84	3.70	2.79	0.12

In the heave decay test, the FPA device was lifted with an initial displacement of $H_{in}=0.02$ m (model scale). In the pitch decay test, the device was initially rotated with an angle of $\alpha_{in}=5.7$ degrees, whereas the initial displacement in surge was minimized. The time histories of the heave and pitch response (α) in the decay test are plotted in Figure 5.

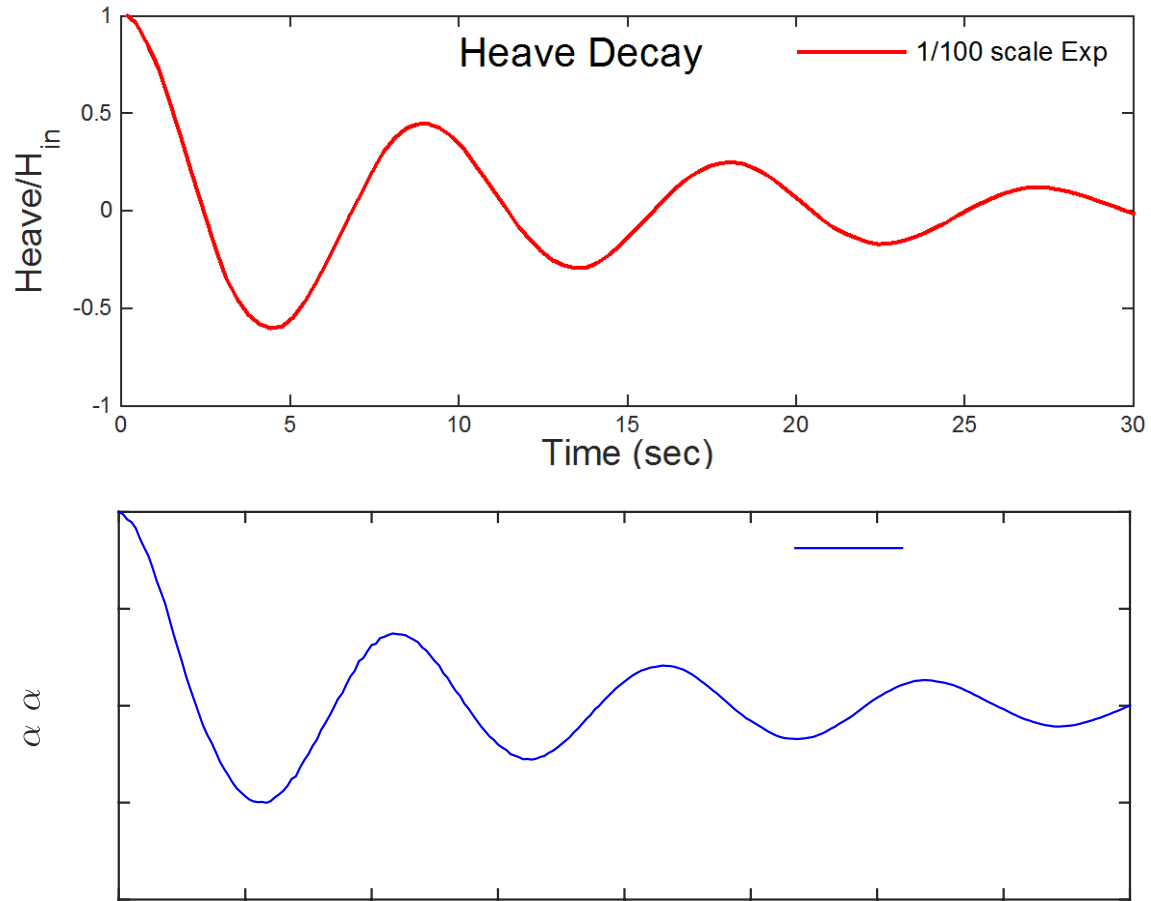

Figure 5. Decay test time histories for the heave (top) and pitch (bottom) responses at full scale (scaled by the initial displacement and rotational angle)

For the tests in regular waves, the response amplitude operators (RAOs) were calculated from five oscillations. To analyze the trend in the hydrodynamic response of the locked model, particularly during the extreme waves, we plotted the RAOs for the designed 9-m and 15-m wave scenarios and the third-order polynomial regressions against the wave frequency, as shown in Figure 6.

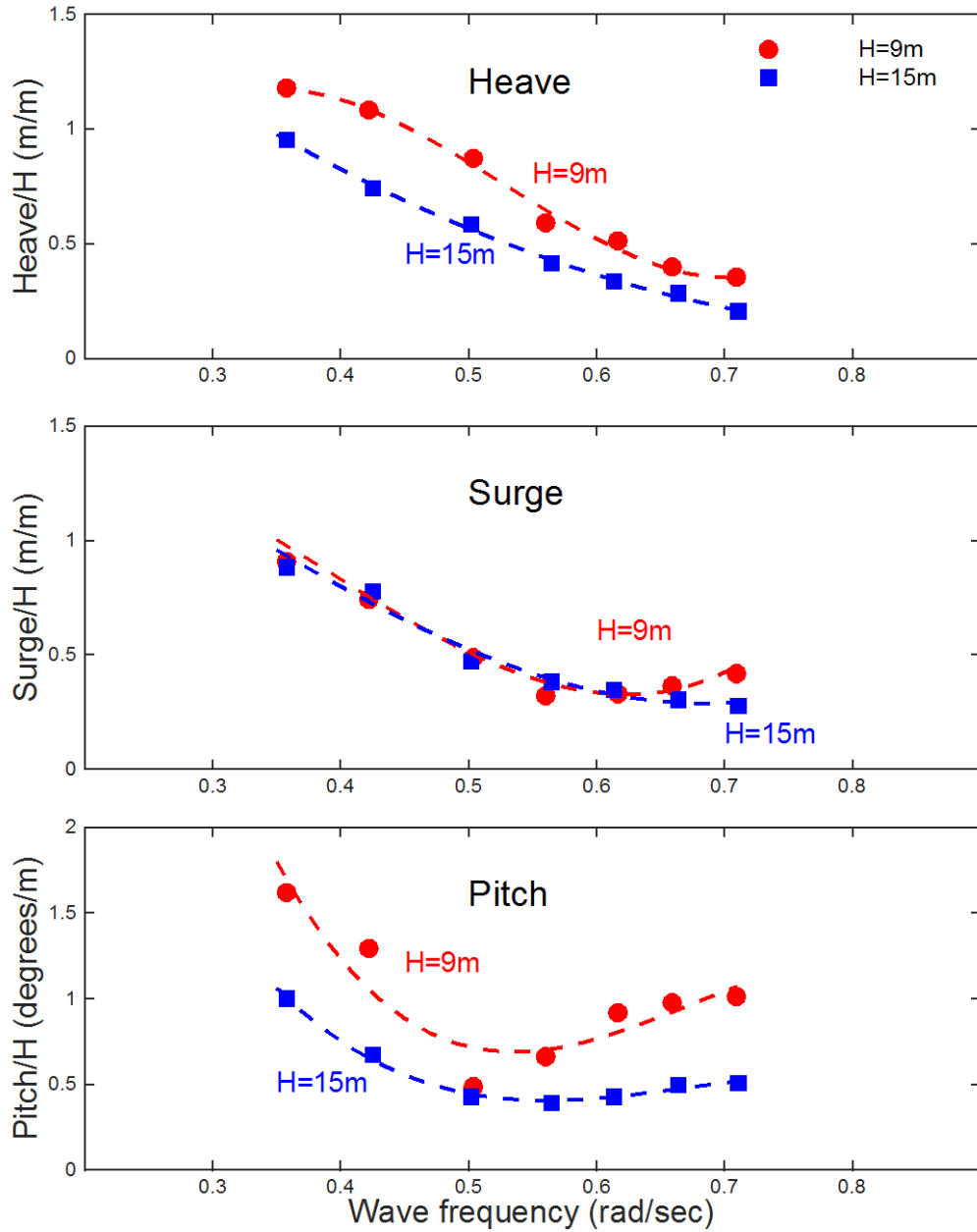

Figure 6. Heave (top), surge (middle), and pitch (bottom) RAOs for the locked FPA (scaled by the wave height)

3 Test #2: Heave-Only FPA Power Performance Test

This set of experimental wave tank tests was conducted at the Scripps Institution of Oceanography at the University of California at San Diego during August 2011. This section presents the test setup and results from the first power performance wave tank test.

3.1 Tank Test Setup

Figure 7 shows the settings and dimensions of the wave tank. Instead of connecting the testing model to the mooring lines, a carriage-connected heave guide was used so that the testing model was constrained to move in heave only.

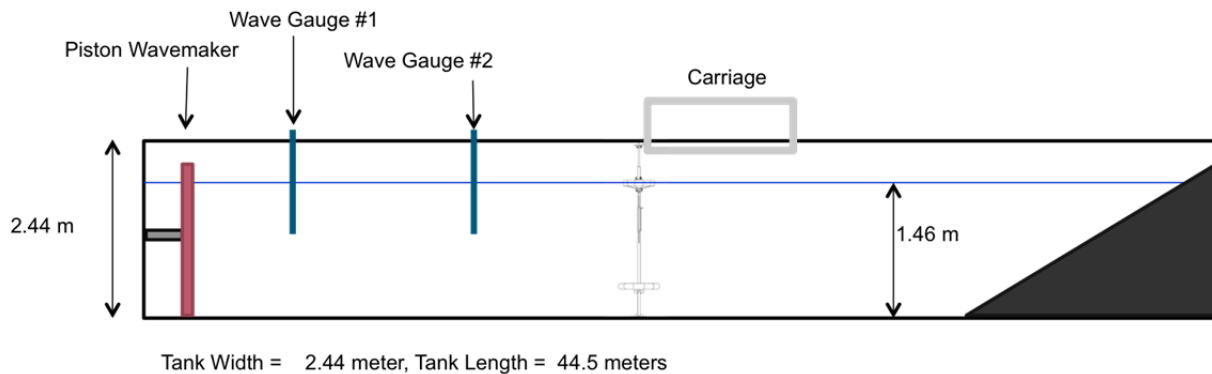

Figure 7. Schematic of the wave tank at the Scripps Institution of Oceanography at the University of California at San Diego

Figure 8 shows the experimental setup for the wave tank tests. A miniature hydraulic cylinder in a closed hydraulic circuit with a needle valve provided damping to the relative motion to represent the PTO system, and the PTO force was measured using a load cell. The potentiometer was used throughout the tests to record the relative motion between the float and reaction plate. The linear potentiometer measurements were also validated by a camera tracking system, which consisted of five cameras that were arranged in a semicircle around the model.

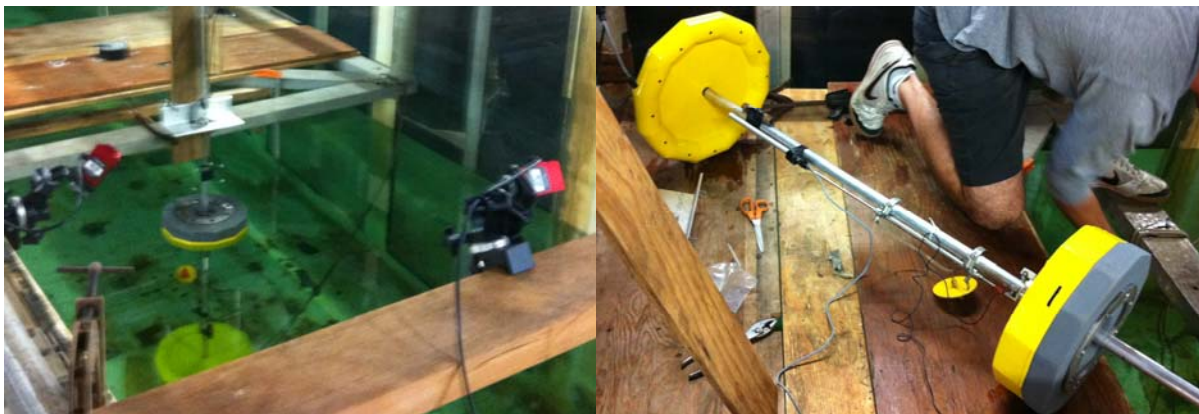

Figure 8. Heave-only FPA wave tank test. Photos by Yi-Hsiang Yu, NREL

A 1/33-scale testing model was used in the study. The dimensions and model properties are shown in Figure 9 and Table 5.

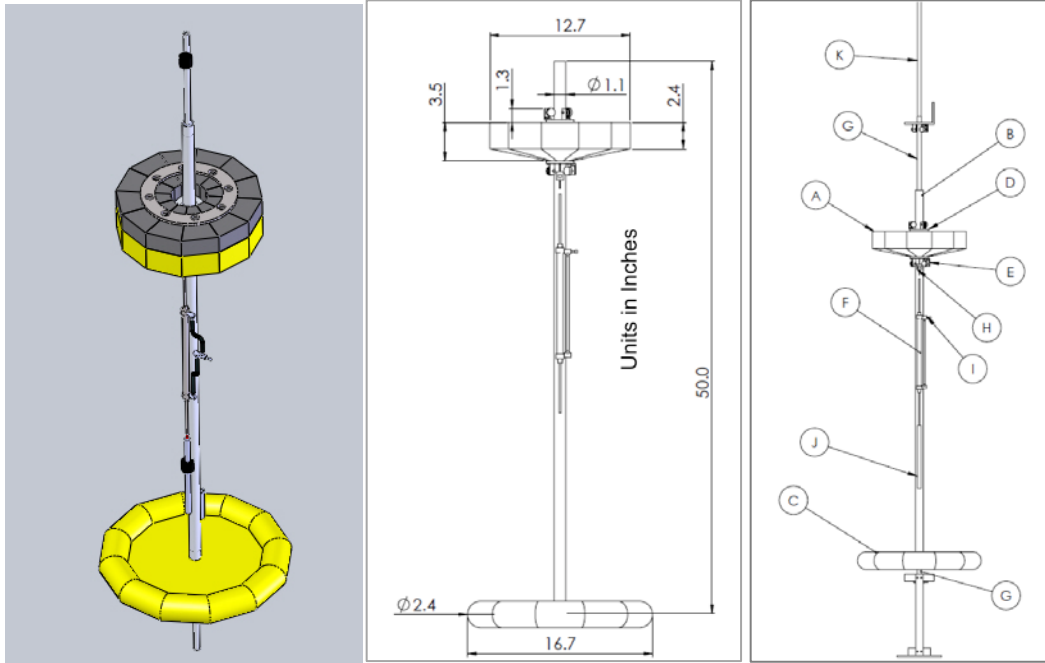

Figure 9. Schematic of the heave-only FPA testing model (model scale)

Table 5. Mass Properties for the Heave-Only Testing Model (Model Scale)

Component		Mass (kg)
Float	A. Float	3.220
	D. Top roller	0.115
	E. Bottom roller	0.117
Spar/plate	B. Central column	0.745
	C. Damping plate	1.108
	F. Cylinder and clamps	0.205
	H. Load cell	0.012
	I. Needle valve	0.015
Not on the testing model	J. Linear pot (short)	0.077
	K. Linear pot (long)	0.114
	G. Heave guides	0.116

3.2 Wave Tank Test Results

Table 6 lists the test cases and measured results for the heave-only FPA power performance trials in regular waves with a wave height of 2.5 m (full scale), a range of wave periods, and PTO damping coefficients.

Table 6. Matrix for the Heave-Only FPA Power Performance Tank Test (Full Scale)

Test Number	Measured Wave Height (m)	Measured Wave Period (s)	Measured RMS Relative Motion (m)	Avg. Power Output Kilowatts (kW)	Estimated PTO Damping Coefficients kilonewton-seconds per meter (kNs/m)
1	2.54	7.91	1.37	154.42	1,041.05
2	2.58	10.08	0.93	62.91	1,511.14
3	2.45	12.03	0.74	27.59	1,460.76
4	2.55	10.05	1.13	75.98	1,209.57
5	2.56	10.07	1.13	78.78	1,257.87
6	2.58	7.94	1.52	193.87	1,067.16
7	2.50	5.92	0.69	68.57	1,034.33
8	2.53	5.98	0.62	67.30	1,254.14
9	2.66	8.00	1.47	184.99	1,116.68
10	2.57	10.02	1.04	75.53	1,430.68
11	2.50	11.93	0.69	27.04	1,642.75
12	2.71	14.05	0.53	14.51	2,028.18
13	2.53	11.82	0.71	30.75	1,729.45
14	2.54	11.85	0.67	30.55	1,911.97
15	2.55	10.06	1.02	77.36	1,525.51
16	2.61	7.87	1.28	195.19	1,501.80
17	2.55	5.97	0.54	56.93	1,425.26
18	2.54	5.97	0.45	48.82	1,707.77
19	2.64	8.02	1.19	196.14	1,814.67
20	2.61	10.01	0.90	76.79	1,919.40
21	2.53	11.89	0.60	27.66	2,209.27
22	2.53	11.94	0.48	21.96	2,791.55
23	2.54	10.00	0.79	69.67	2,288.26
24	2.64	7.95	0.94	175.19	2,549.57
25	2.61	6.01	0.36	39.32	2,181.83
26	2.64	8.01	1.43	148.71	939.85

The power output was calculated as the product of the PTO force and the relative velocity between the float and the reaction plate, as in

$$P = F_{PTO} \times u_{rel}$$

where P is the power, F_{PTO} is the measured PTO force, and u_{rel} is the relative velocity between the float and spar/plate. The averaged power was calculated as the integration of the instantaneous power over time divided by the relevant signal duration, after the transient response had damped out and only the steady-state response remained. The PTO damping was adjusted by turning the needle valve of the hydraulic circuit. Note that the PTO forces from the tank test showed a higher force on the compression stroke than the extension stroke and needle

valve PTO design did not provide a linear constant damping coefficient for each case. For simplicity, we estimate the averaged PTO damping coefficient by assuming that the relative motion is close to a harmonic function, which gives

$$C_{PTO} = \frac{2P}{(\omega A_{rel})^2}$$

where A_{rel} is the measured amplitude of the relative motion between the float and the spar/plate and ω is the incident wave frequency.

For PTO damping coefficients between 1,500 kilonewton-seconds per meter (kNs/m) and 2,000 kNs/m, we plotted the relative heave motion between the float and spar/plate and the calculated power output (scaled by H^2) against wave frequency in Figure 10 and Figure 11, respectively. Third-order polynomial regressions were used to represent the trend of the relative motion and power output with respect to the wave frequency.

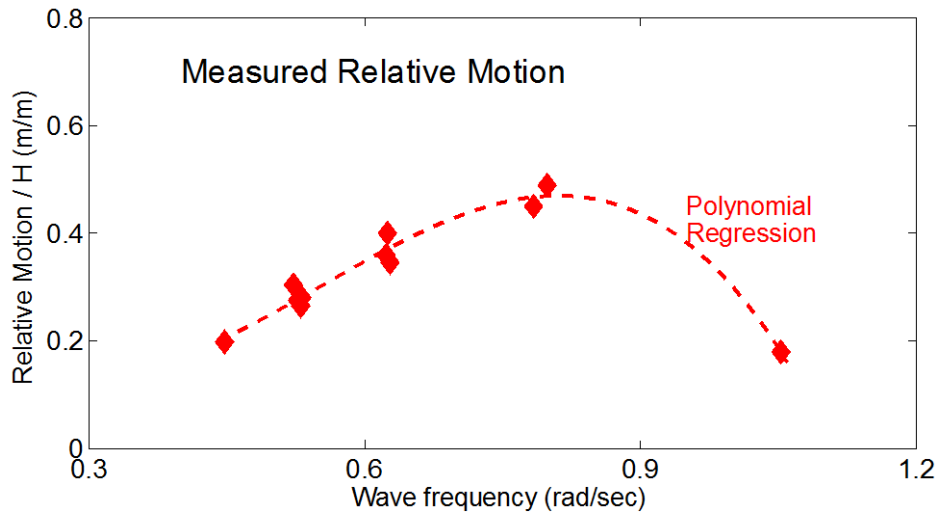

Figure 10. Relative heave RAO for the heave-only FPA at full scale

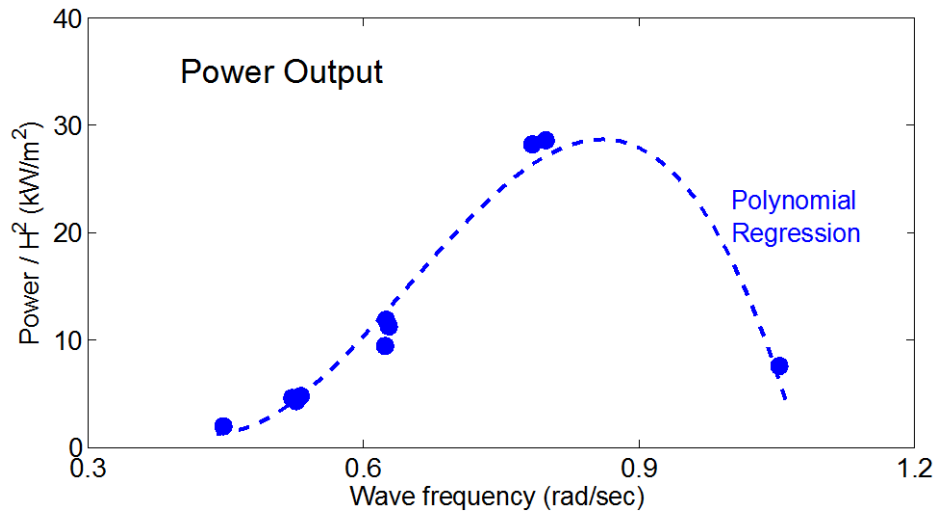

Figure 11. Power output for the heave-only FPA at full scale

4 Test #3: Moored FPA Power Performance Test

Like the heave-only FPA power performance test, the moored FPA power performance test was conducted at the Scripps Institution of Oceanography at the University of California, San Diego. This experimental wave tank test took place during November 2011. This section presents the test setup and results from the second power performance wave tank test.

4.1 Tank Test Setup

Figure 12 shows the experimental setup for this wave tank test. The testing model was connected to a set of four mooring lines (Table 7) and each mooring line was connected to one of four metal piles located on the sidewall. This mooring setup was similar to that used in the locked FPA wave tank test; however, only four mooring lines (single layer) were used for this study rather than the eight mooring lines (two layers) used in the locked FPA wave tank test conducted at the University of California at Berkeley.

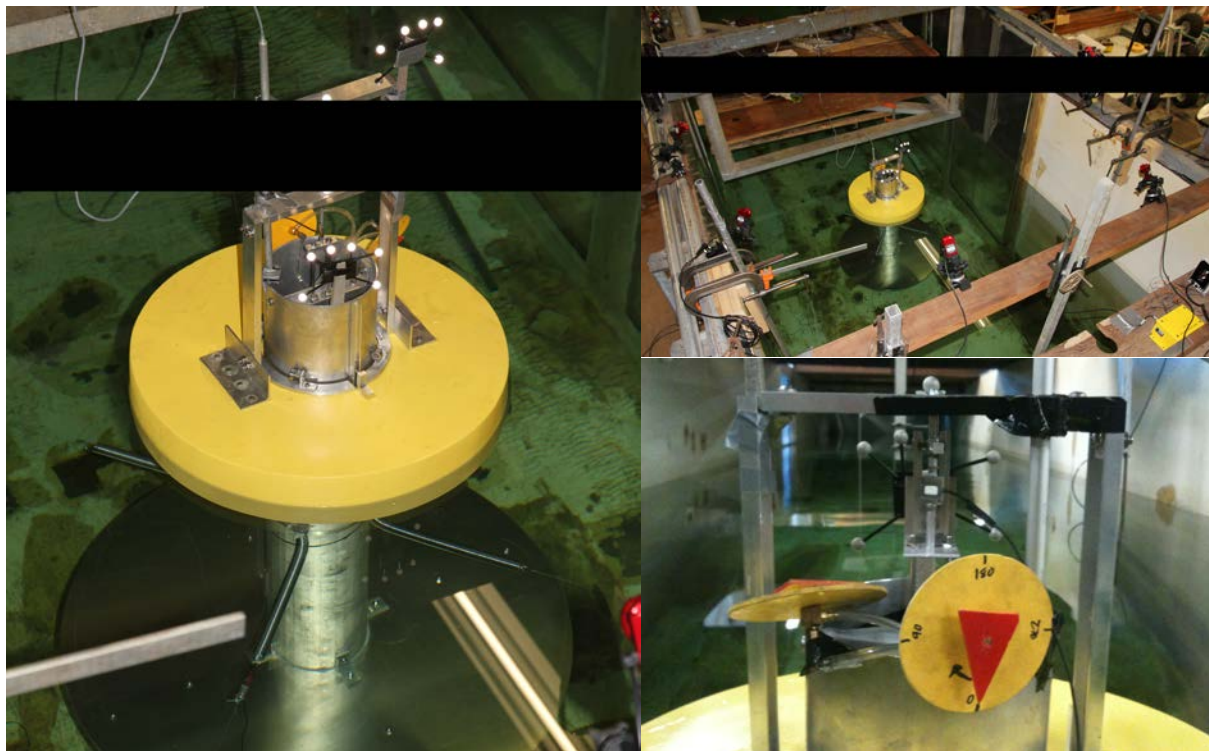

Figure 12. Moored FPA power performance test setup. Photos (clockwise from left) by Mike Lawson, Mike Lawson, and Yi-Hsiang Yu

Table 7. Mooring Line Configuration (Model Scale)	
Mooring Settings	1/33-Scale Model
Connect to	Spar/plate
Connection location	≈ 0.5 m below mean free surface
Spring stiffness	≈ 0.06 kN/m (each line)

The dimensions and mass properties of the (1/33-scale) FPA testing model are presented in Figure 13 and Table 8. The mass properties included the mass of the device structure and ballast. We assumed that both the float and center spar with plate were located at their equilibrium positions.

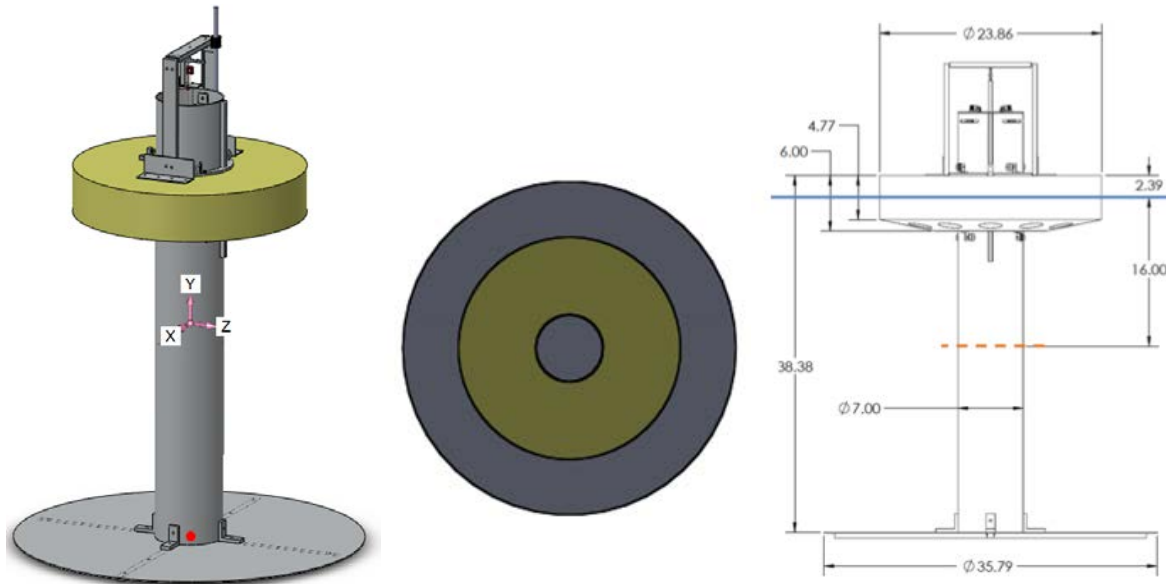

Figure 13. Schematic of the two-body FPA (in inches)

Table 8. Mass Properties for the Moored Testing Model (Model Scale)

Component		Mass (kg)	Center of Gravity (m)	Diagonal Moment of Inertia at the Center of Gravity (kgm ²)
Float		20.23	[0,0,-0.022]	[0.53,0.54,0.95]
Spar/plate	Reaction plate and column	12.38	[0,0,-0.65]	[3.5,3.5,0.73]
	Spar ballast	9.70		
	PTO	3.24		
	Linear pot	0.08		

Figure 14 shows a schematic of the PTO design used in the tank test. A hydraulic piston with multiple orifices was used to represent the PTO in the tank test. The orifices could be opened and closed to control the PTO damping to the system. The PTO was placed inside the column with the top end of the cylinder approximately 25 cm below the column top. We used a 0.4-kilonewton (kN) load cell responding only to axial tension and compression to measure the PTO damping. Note that the PTO damping from the orifice design was still nonlinear. Nevertheless, the orifice design provided better control of the damping coefficient, so the damping would not be influenced by the flow around the model caused by the model motion and incoming waves.

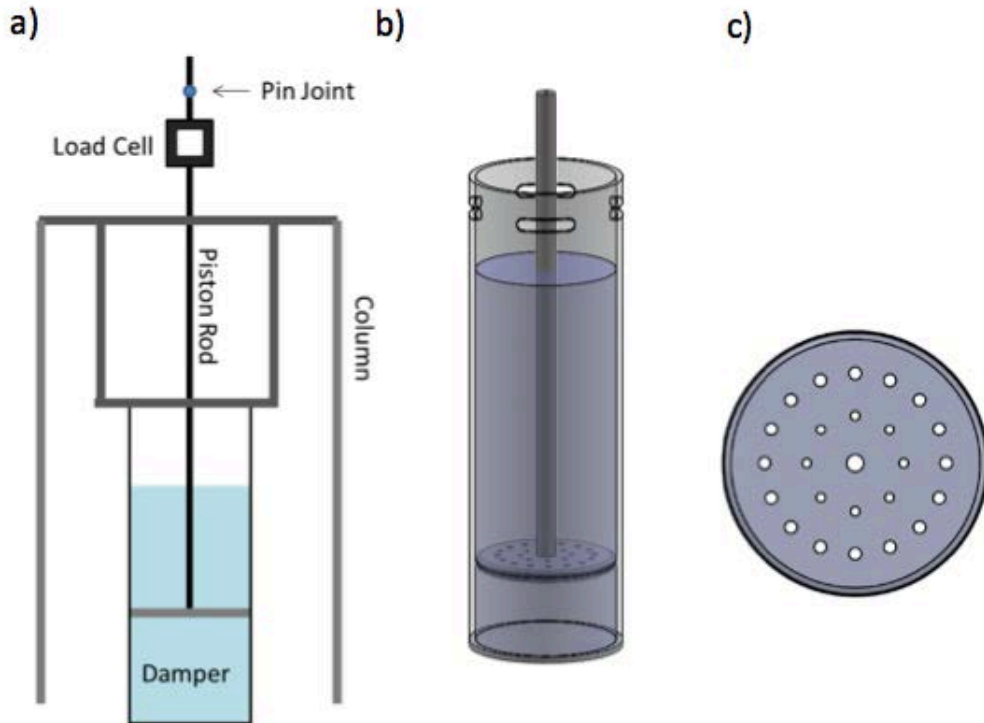

Figure 14. PTO design: (a) configuration schematic, (b) hydraulic piston, and (c) orifice design inside the piston. *Illustrations from Previsic, Shoele, and Epler 2014*

4.2 Wave Tank Test Results

Table 9 shows the test case and measured results from the moored FPA power performance wave tank test during regular waves with a target wave height of 3 m (full scale) and a range of wave periods. The tank test was performed for a range of PTO damping coefficients to maximize the design power output. The power output was calculated by multiplying the PTO force with the relative velocity between the float and reaction plate following the equation presented in the heave-only FPA power performance test section.

To analyze the power output and the relative heave motion between the float and spar/plate, the selected results were grouped into two sets of PTO damping coefficients and plotted against the wave frequency, as shown in Figure 15 and Figure 16. The lower value set ranged from 2,000 kNs/m to 2,500 kNs/m, and the higher set ranged from 6,100 kNs/m to 8,100 kNs/m. Third-order polynomial regressions were also used to represent the trend of the relative motion and power output.

Table 9. Matrix for the Moored FPA Power Performance Tank Test (Full Scale)

Test Number	Measured Wave Height (m)	Measured Wave Period (s)	Measured RMS Relative Motion (m)	Avg. Power Output (kW)	Estimated PTO Damping Coefficients (kNs/m)
1	2.89	8.01	1.29	445.61	3,454.43
2	2.91	7.99	0.66	278.29	8,173.09
3	2.85	12.06	2.10	190.65	1,272.97
4	3.04	13.95	2.10	118.00	1,051.02
5	2.89	12.03	2.21	90.31	541.00
6	2.86	12.04	2.18	128.40	793.36
7	3.02	8.01	1.34	502.35	3,662.68
8	3.04	11.97	1.94	446.37	3,456.58
9	3.06	17.93	1.71	103.46	2,302.43
10	3.13	18.05	1.00	104.18	6,920.91
11	2.88	10.02	1.37	561.70	6,100.71
12	3.10	12.02	1.63	554.08	6,119.01
13	2.92	12.04	1.40	538.16	8,080.95
14	3.04	14.00	1.43	357.54	6,954.87
15	2.99	17.91	1.19	109.53	4,992.32
16	3.07	8.02	1.65	538.58	2,577.32
17	2.89	10.05	1.99	467.75	2,425.97
18	2.88	8.97	1.97	632.07	2,645.85
19	2.90	10.98	2.09	410.75	2,306.68
20	2.93	12.00	2.08	319.47	2,143.78
21	2.88	16.05	2.08	138.80	1,667.15
22	3.01	10.99	1.36	592.16	7,845.68
23	2.96	12.08	1.47	563.34	7,738.28
24	3.06	13.97	1.48	368.81	6,703.53
25	3.00	17.88	1.25	113.82	4,751.38
26	3.03	7.99	1.69	543.60	2,471.90
27	3.07	10.04	2.07	498.45	2,378.72
28	3.06	10.96	2.12	410.95	2,228.63
29	2.90	11.97	2.11	314.56	2,056.72
30	3.01	14.05	2.07	184.12	1,723.74
31	2.85	16.03	2.10	134.85	1,590.63
32	2.96	8.01	2.12	494.30	1,436.86
33	2.99	17.91	2.13	50.06	718.62

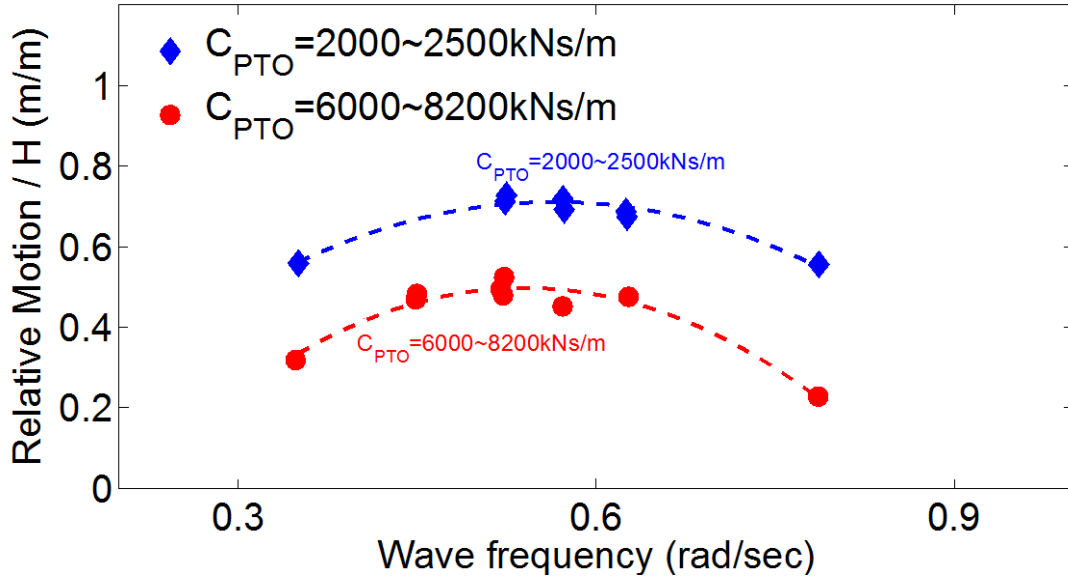

Figure 15. Relative heave RAO of the model at full scale

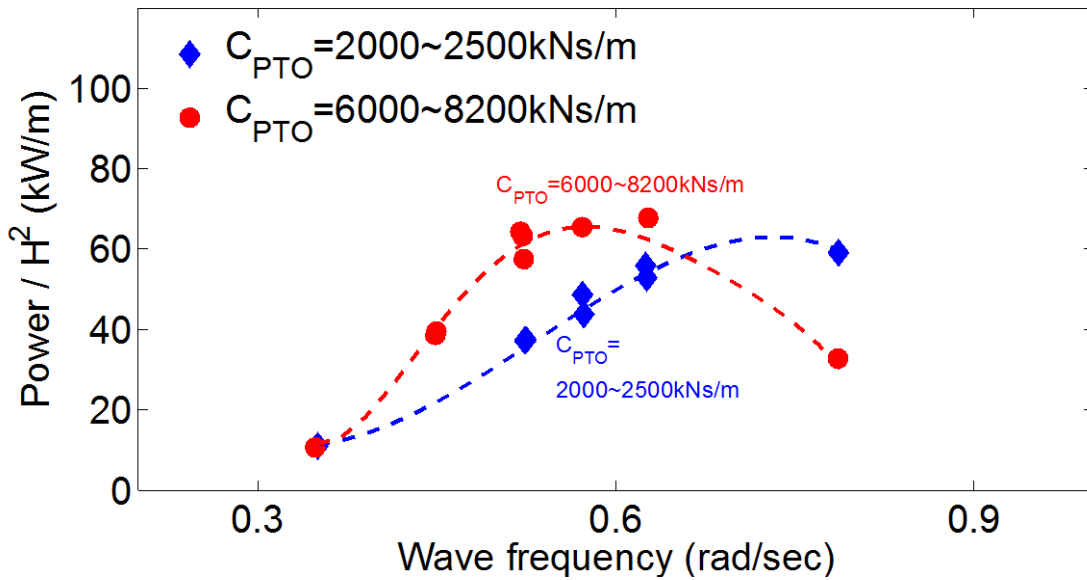

Figure 16. Power output of the model at full scale

5 Summary

This report is a supporting document for the RM project report (Neary et al. 2014), and it describes the experimental wave tank tests conducted during the RM3 floating-point absorber wave energy converter study. As part of that project, three sets of experimental wave tank tests were conducted to study FPA wave energy converter systems during both operational and extreme sea states. This report documents the wave tank test setup, model dimensions and properties, and the analyzed data sets. The analyzed data sets include a list of test cases, hydrodynamic response, and the estimated power output.

References

Neary, V.S.; Previsic, M.; Jepsen, R.A.; Lawson, M.J.; Yu, Y.-H.; Copping, A.E.; Fontaine, A.A.; Hallett, K.C.; Murray, D.K. (2014). *Methodology for Design and Economic Analysis of Marine Energy Conversion (MEC) Technologies*. Albuquerque, New Mexico: Sandia National Laboratories.

Previsic, M.; Shoele, K.; Epler, J. (2014). “Validation of Theoretical Performance Results Using Wave Tank Testing of Heaving Point Absorber Wave Energy Conversion Device Working Against a Subsea Reaction Plate.” *Second Marine Energy Technology Symposium Proceedings*; August 15–18, 2014, Seattle, Washington.

Ruehl, K.; Michelen, C.; Kanner, S.; Lawson, M.; Yu, Y.-H. (2014). “Preliminary Verification and Validation of WEC-Sim, an Open-Source Wave Energy Converter Design Tool.” *33rd International Conference on Ocean, Offshore and Arctic Engineering Proceedings*; June 8–13, 2014, San Francisco, California. New York: American Society of Mechanical Engineers.

Yu, Y.-H.; Lawson, M.; Ruehl, K.; Michelen, C. (2014a). “Development and Demonstration of the WEC-Sim Wave Energy Converter Simulation Tool.” *Second Marine Energy Technology Symposium Proceedings*; August 15–18, 2014. Seattle, Washington.

Yu, Y.-H.; Li, Y. (2013). “Reynolds-Averaged Navier-Stokes Simulation of the Heave Performance of a Two-Body Floating-Point Absorber Wave Energy System.” *Computers & Fluids* (73); pp. 104–114.

Yu, Y.-H.; Li, Y.; Hallett, K.; Hotimsky, C. (2014b). “Design and Analysis for a Floating Oscillating Surge Wave Energy Converter.” *33rd International Conference on Ocean, Offshore and Arctic Engineering Proceedings*; June 8–13, 2014, San Francisco, California. New York: American Society of Mechanical Engineers.