



Sandia National Laboratories

Energy Storage Technologies Overview



Ramesh Koripella, Ph.D.

MN PUC webinar, June 10, 2026



This material is based upon work supported by the U.S. Department of Energy, Office of Electricity (OE), Energy Storage Division.



Sandia National Laboratories is a multimission laboratory managed and operated by National Technology & Engineering Solutions of Sandia, LLC, a wholly owned subsidiary of Honeywell International Inc., for the U.S. Department of Energy's National Nuclear Security Administration under contract DE-NA0003525.

SAND2026-22209PE



WEBINAR 1: Energy storage technologies overview - WED JUNE 10

Holistic **overviews of existing and emerging battery technology** integral to energy storage systems (ESSs)

Lithium-ion Batteries

Flow Batteries

Sodium-Based Batteries.

Lead-Acid Batteries

Solid-State Batteries

Comparisons of lithium-ion based and non-lithium batteries

Performance Characteristics of battery ESS:

Redundancy, Round-trip efficiency, Safety (e.g., fire risks), Energy Capacity, Power Capacity
Cycle Life and Calendar Life, Depth of Discharge (DoD), Response Time to help with emergency responses, State of Health (SoH) and State of Charge (SoC), Recycling considerations

Technology Readiness Levels (TRL)

Details of these will be covered in future sessions

FTM versus BTM energy storage systems Utility case studies

Other specific technology/software for storage system operations

Outline



- Introduction
- Energy Storage Technologies Overview
 - Lithium-ion Batteries
 - Flow Batteries
 - Sodium-Based Batteries.
 - Lead-Acid Batteries
 - Solid-State Batteries
- Performance Characteristics of a Battery ESS
- Brief overview of other technologies (mechanical and thermal storage)
- Summary
- Q &A

Feel free to interrupt for any questions as we go along.

ENERGY STORAGE R&D AT SANDIA



BATTERY MATERIALS

Large portfolio of R&D projects related to advanced materials, new battery chemistries, electrolyte materials, and membranes.



DEMONSTRATION PROJECTS

Work with industry to develop, install, commission, and operate electrical energy storage systems.



CELL & MODULE LEVEL SAFETY

Evaluate safety and performance of electrical energy storage systems down to the module and cell level.



STRATEGIC OUTREACH

Maintain the ESS website and DOE Global Energy Storage Database, organize the annual Peer Review meeting, and host webinars and conferences.



POWER CONVERSION SYSTEMS

Research and development regarding reliability and performance of power electronics and power conversion systems.

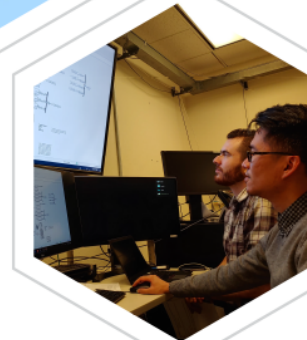

GRID ANALYTICS

Analytical tools model electric grids and microgrids, perform system optimization, plan efficient utilization and optimization of DER on the grid, and understand ROI of energy storage.



SYSTEMS ANALYSIS

Test laboratories evaluate and optimize performance of megawatt-hour class energy storage systems in grid-tied applications.

Wide ranging R&D covering energy storage technologies with applications in the grid, transportation, and stationary storage

Electric Grid and Energy Storage



Electric Grid as of early 2026:

- The US Electric grid is ~1.3 TW capacity.
- Total US electricity generation: 0.51 TW/4429 TWh electricity.
- Forecast is for increasing electricity demand with increased data center load growth.
- MN generated 61 TWh of electricity (~1.4% of US total). Approximately tracking the % of US population

Why Energy Storage?

- Electric grid runs in a balance of supply and demand. Large thermal power plants (coal, nuclear, nat. gas) supply base load, Peaker plants (nat. gas), spin reserve, **energy storage** helps meet the variations in load.
(for resiliency, prepare for unpredictable weather events, reduce curtailments and grid services such as frequency response, energy shift, reactive power and voltage control, black start etc.)

Electric Grid and Energy Storage



Electricity Generation mix in the US and MN (EIA 2025 data)

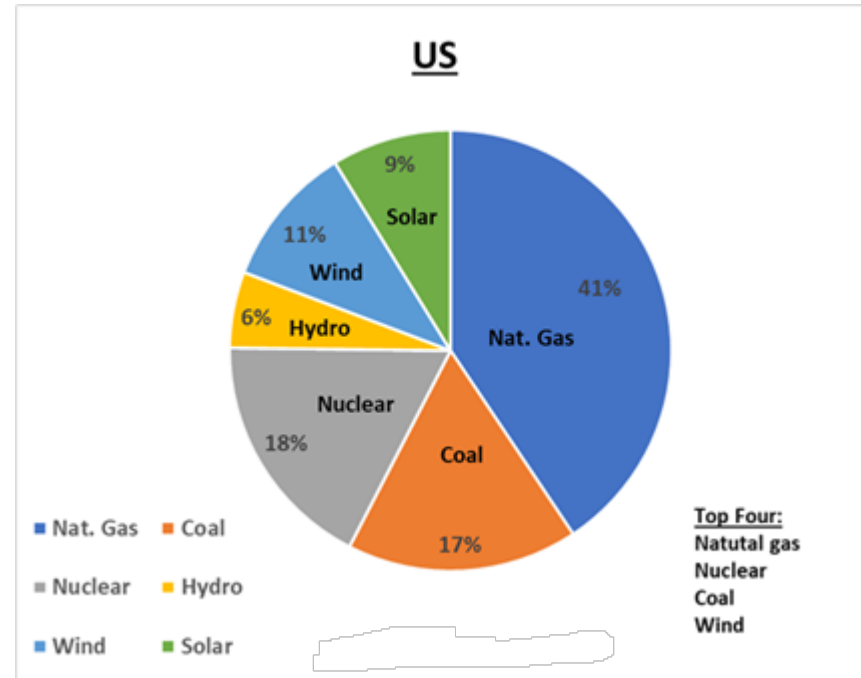
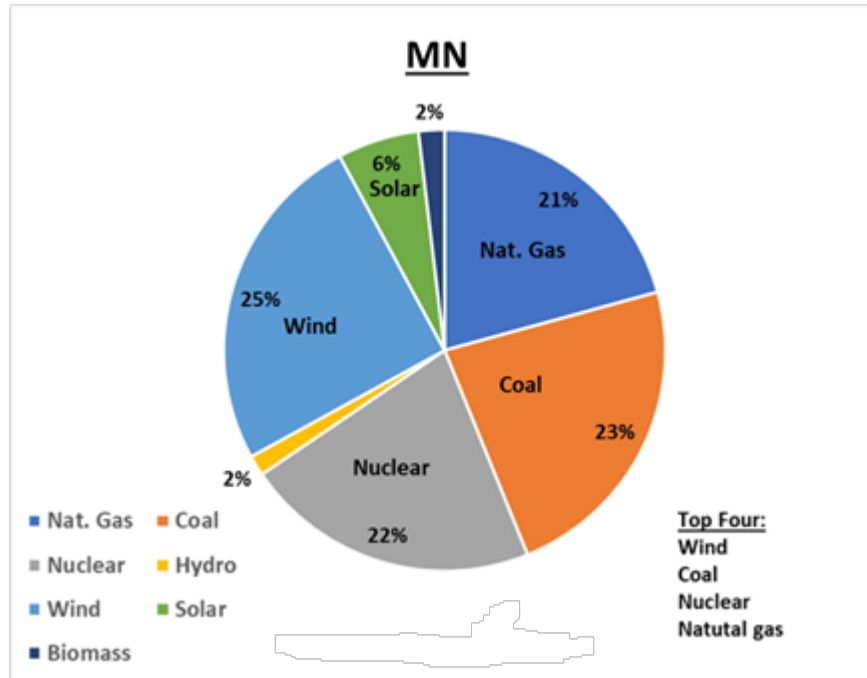

In the total generation mix: Variable ~19%(US), ~32% in MN (25% wind and 6% solar).

As of early 2026, Grid scale energy storage:

- The total US grid scale battery storage in the US is ~50 GW/144 GWh (mostly 2-4 hr batteries).
- Pumped Hydro Storage (PHS): 23 GW/550 GWh (~24 hr).
- Total energy storage (144+550 = 694 GWh) is <2% total US electricity generation (4430 TWh). More storage is needed.
- MN Battery storage is 23 MW (~80 MWh), a very small percent of total generation 61 TWh. Several projects are in pipeline. MN doesn't have much PHS.

Long Duration Energy Storage (LDES) Classifications



- **Storage Classifications** (following the DOE report – *Pathways to commercial Liftoff: Long Duration Energy Storage, Mar 2023*):
 - **Short Duration: ≤ 4 hrs**, - Li ion batteries, mechanical storage technologies (fly wheels, Pumped Hydro Storage (PHS))
 - **Inter-day LDES: 10-36 hrs** (all mechanical storage, electrochemical technologies such as flow batteries, Metal-air batteries, Li-ion for 10 hrs duration and beyond is expensive)
 - **Multi-day/week LDES: 36-160+ hrs** (thermal storage, electrochemical technologies (flow batteries, metal- air))
 - **Seasonal Storage: Several months** (primarily chemical storage – hydrogen, ammonia, methane or natural gas with carbon capture)
- **There are few other different storage classifications in use: for example;**
 - Short ≤ 4 hr, Medium 4-10 hrs, and LDE 10+ hrs

FTM versus BTM Energy Storage Systems



- **Front of the meter (FTM)** systems sit on the utility side. Large-scale projects (100's of MW). Ex: Solar farms, wind turbines with large utility scale battery banks.
- They feed directly into the grid to provide generation, stability, and utility scale services.

- **Behind the meter (BTM)** systems are located on the customer's side of the utility meter. Generally smaller in size (kW range)
- They are mostly solar and battery storage (ex: roof top solar and a Tesla power wall) designed to reduce consumption and lower bills and provide resilience.
- Some of these can be combined into a microgrid or aggregated distributed energy resource (ADER) to offer grid services.

Applications Served by large-scale battery storage



EIA 2022 data. Ranking is similar in 2025 also.

Figure 12. Applications served by large-scale battery storage (2022)

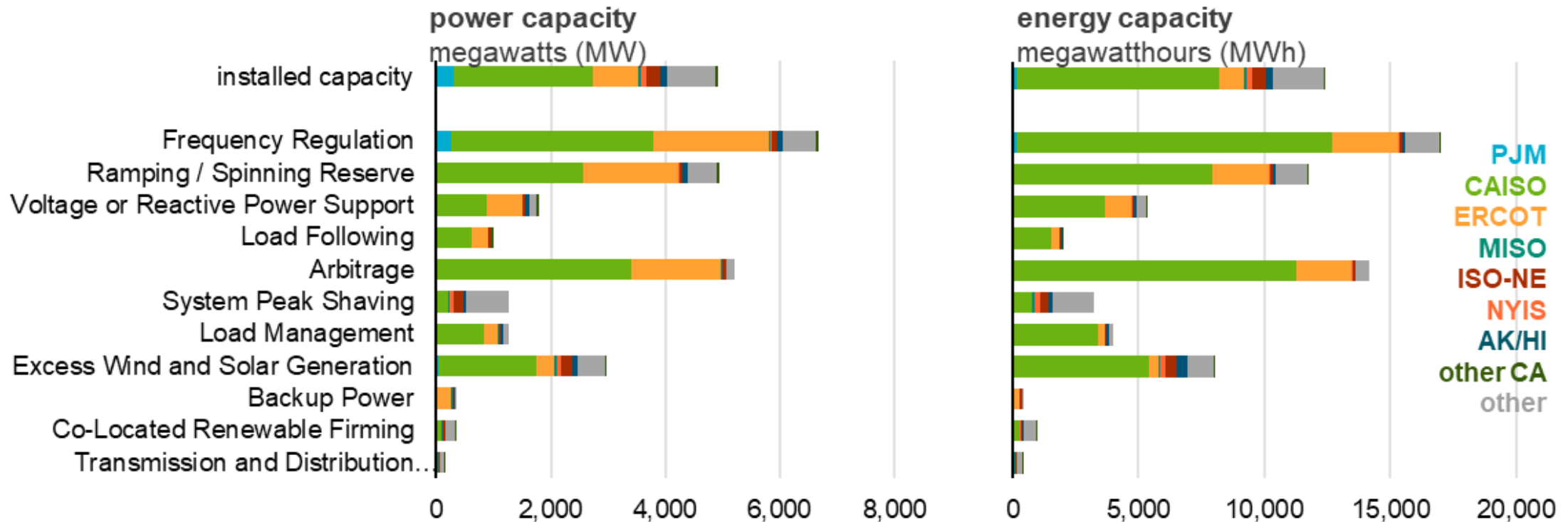

Data source: U.S. Energy Information Administration, 2022 Form EIA-860 Early Release, Annual Electric Generator Report

Top Applications of BESS: *Frequency Regulation, Arbitrage, Spinning Reserve*

Grid Scale Energy Storage Applications- Energy and Power applications



“Energy” applications >30 min. time scale,
long duration of energy, fewer cycles

“Power” applications <15 min. time scale,
fast control of the electric grid, many cycles

Energy Applications

Power Applications

Arbitrage

Frequency regulation

 energy time shift

Voltage support

Demand charge reduction

Small signal stability

Time-of-use charge reduction

Frequency droop

T&D upgrade deferral

Synthetic inertia

Grid resiliency

Renewable capacity firming

- **Energy applications** involve continuous storage system discharges over periods of hours and correspondingly long charging periods. They typically involve **one or two charge-discharge cycle per day**.
- **Power applications** involve comparatively short periods of discharge (sec to minutes) and short recharging periods, often requires **many cycles per day**.
- ***We need to evaluate and select the energy storage system for the application requirements.***

(for example, Form Energy claims it is targeting energy application. They do not want to compete with Li battery in power application. It is positioning as a supplement to it for grid reliability (under multiple day uncertainties), rather than participating in power application. Li ion battery can meet both, but for very long durations it gets expensive and raises safety concerns.)

Few Technology Options for Energy Storage



Electrochemical Storage (Batteries - short, medium, long duration storage)

- **Lithium-Ion Batteries,**
- Sodium-Ion Batteries, Molten Sodium Batteries
- Zn-Based Batteries, Ni-H₂ batteries, Pb acid batteries
- Metal-Air Batteries
- Flow Batteries
- Supercapacitors

Mechanical Storage (short, medium, long duration storage)

- **PHS (Pumped Hydro Storage)**
- Variations of PHS (Quidnet Energy, RCAM)
- Gravity (ARES, Energy Vault)
- Compressed air (CAES)
- Flywheels (short duration storage)

Thermal Storage (medium, long duration storage)

- Molten salt thermal storage, ceramic particle storage media, Fixed bed thermal storage
- Heated brick (Antora, Rondo)
- Molten metal, liquid metal battery
- Liquid air energy storage

Chemical and Hydrogen Storage (long duration and seasonal storage)

- H₂ generation (Electrolysis, SMR), H₂ storage, Electric Power generation (H₂ combustion, Fuel cells)
- Hydrocarbon or ammonia conversion

Desired ES Characteristics:

- **Ability to respond quickly for load demand**
- **High round trip efficiency**
- **Low self discharge**
- **High energy density**
- **Cost competitive**
- **Environment friendly**
- **Availability with good supply chain**
- **Safe**

Electrochemical Cell (or Battery) – example: Li-ion cell

12



Electrochemical cell:

- Consists of two electrodes, anode and cathode in an electrolyte, separated by an ion conducting separator. Electrons flow through the outer circuit.
- During discharge electrons and ions flow from anode to cathode and during charge electrons and ions are forced to move from cathode to anode with the application of applied electric field.

Key Components:

- **Anode:** Graphite, Si, LiTiO_x , Li
- **Cathode:** layered metal oxides, phosphates (LiNiCoAlO_2 , LiNiMnCoO_2 , LiFePO_4)
- **Separator:** polyethylene (PE) or polypropylene (PP) or a combination.
- **Electrolyte:** Li salt such as LiPF_6 dissolved in organic solvents (EC, DMC and DEC)
- **Current collectors:** Cu and Al

Key Characteristics:

- **Voltage** (V, volts) – determined by the reaction between the electrodes and the electrolyte
- **Current** (I, amps) – reaction rate (Amp = Coulombs/sec)
- **Power** (W, watts): $V \times I$
- **Capacity** (Ah or Wh): power as a function of time
- **RTE (%)**: energy out during discharge/ energy in during charge
- **Self discharge**: typically expressed as % degradation/yr under open circuit conditions
- **Degradation**: cycle life (# charge/discharge cycles), calendar life (yrs)

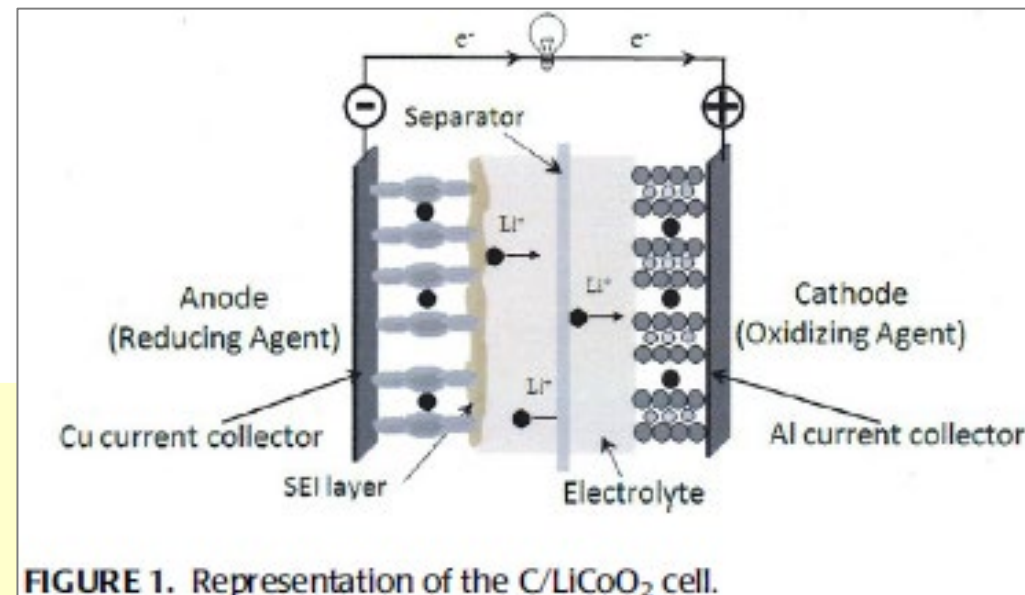

FIGURE 1. Representation of the C/LiCo₂ cell.

Electrochemical Cell or Battery – few fundamentals



- What determines the cell voltage?
 - Here we are referring to single cell voltage.
 - Battery packs are prepared by combining several single cells in series (to boost voltage) and in parallel (for current). It also includes BMS and few safety components.

- What is the electrolyte stability window?
 - Differences in aqueous electrolytes and organic electrolytes.
 - Why the current collectors are Cu at anodes and Al at cathodes in Li ion batteries?

- What is the role of SEI (secondary electrolyte interface) layer in Li ion batteries?
 - Why can't we ship Li ion batteries at zero charge? Or fully discharge the Li ion battery?

- What is voltage versus current behavior for the electrochemical cells?
 - Open circuit voltage, load voltage, voltaic efficiency
 - What is the operating window? What limits the current output?

Electrochemical Cell - Voltage, Current



Cell Voltage,
V stability
window

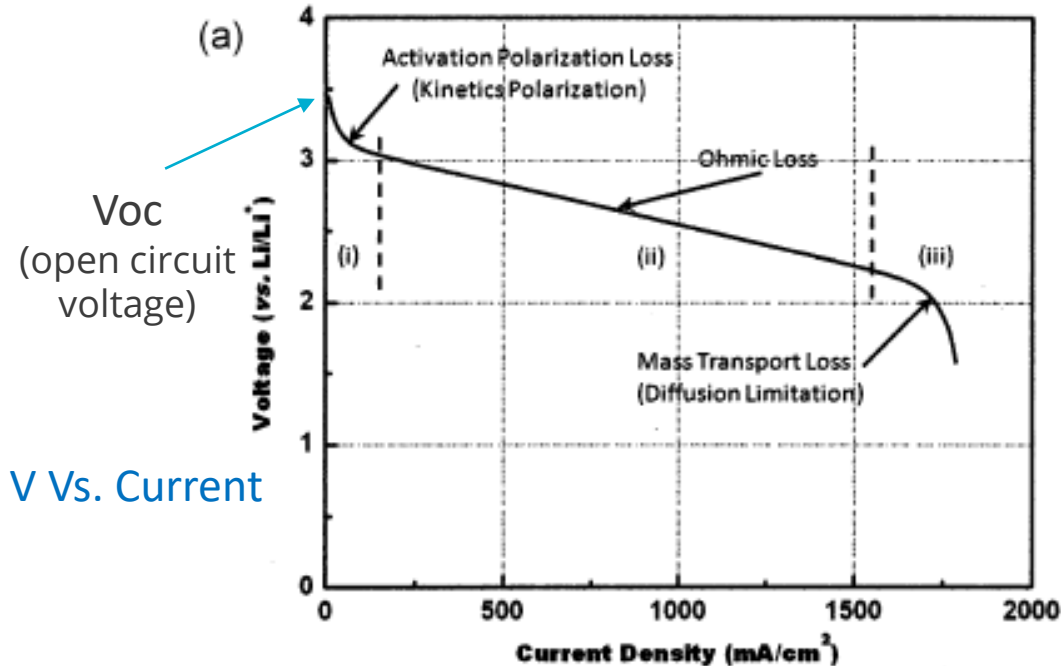
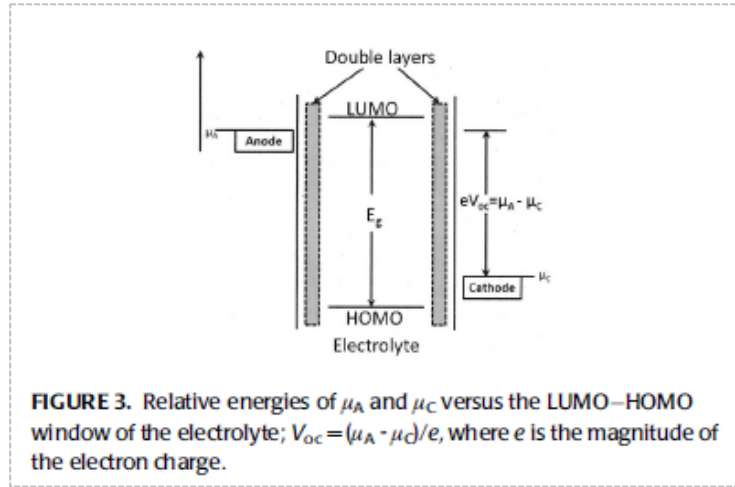

V Vs. Current

Li-ion technology choices

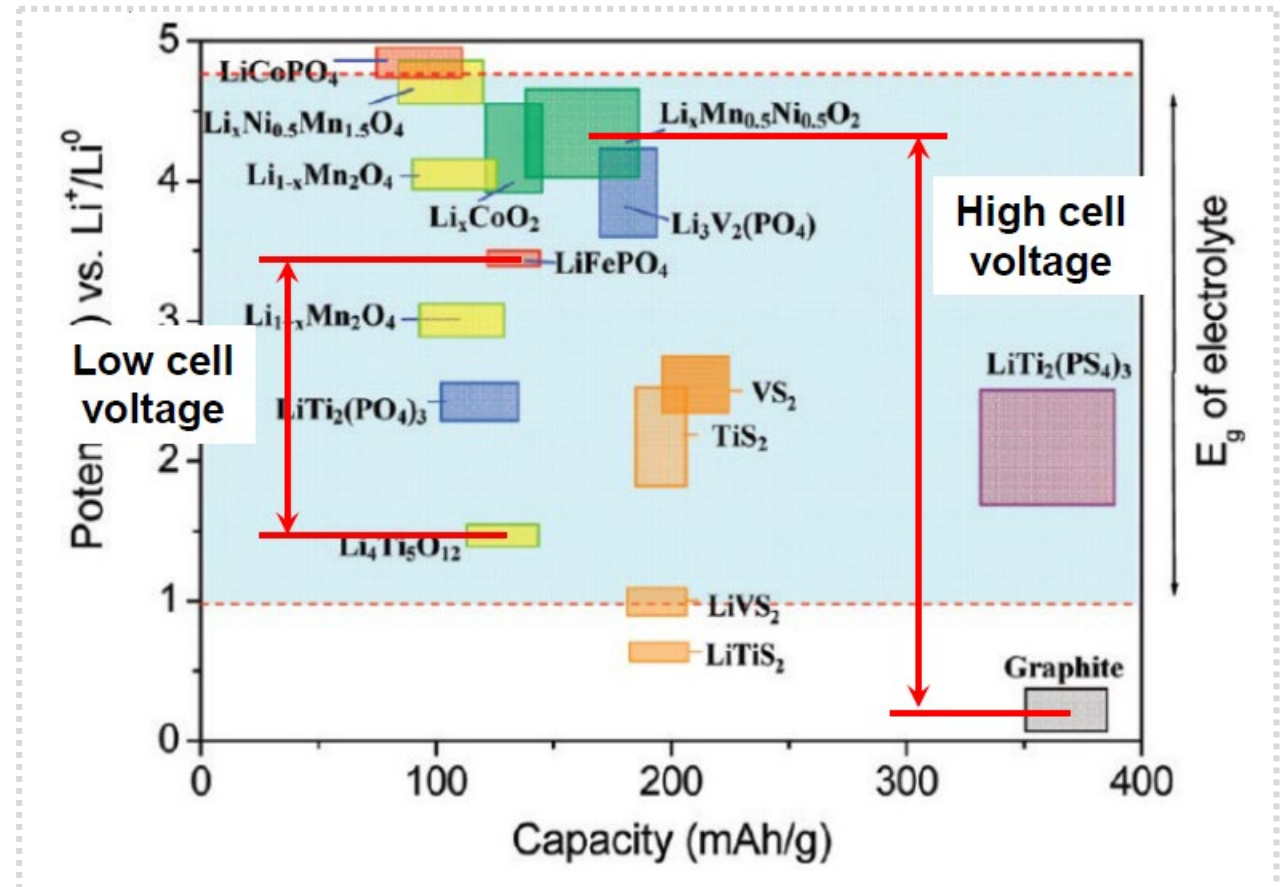

Different chemistries, cell V output, electrolyte stability window

- LFP is more stable, but low voltage (thus low ED), lower cost.

Electrochemical Cell or Battery – few fundamentals



Power Capacity: How many **W** (Amp x Volt) of power or sometimes the **A** at a particular **V**. the battery can deliver. Also referred to as battery C rate (current that can be drawn)

Energy Capacity: How many **Wh** or sometimes how many **Ah** at a particular **V** the battery can last.

C rate: for example for a 10Ah battery, 1C rate is deliver 10A in 1hr, C/2 rate is 5A in 2hr, 2C rate is 20A in 30 mins. So on for other C rates. Operating C ranges depends on the type of battery and specifications.

Cycle Life: How may charge/discharge cycles the battery can deliver the specified power. Typically, capacity drop below 80% is defined as the end of life. Li battery cycle life: 2000-3000 cycles, Pb-acid battery: <1000 cycles.

Calendar Life: # of years the battery is useful. Even without cycling, other degradation mechanisms will slowly degrade the battery.

State of Charge (SoC): Capacity of the battery as percentage of total battery capacity.

Depth of Discharge (DoD): During discharge how much lower voltage can we take the battery, expressed as the % of battery capacity. Inverse of SoC. Ex: 100Wh battery, 75Wh used. Then DoD: 75% and SoC is 25%.

For Pb acid batteries, degradation is faster if DoD>50%, meaning the full capacity is often not available. For Li ion batteries optimum operating range for longer life is 20-80% charge.

State of Health (SoH): % of battery current capacity compared to original condition. For EVs, SoH below 70-80% is considered end of life.

Li-ion Batteries



- They are ubiquitous in consumer electronics, mobile devices and EVs
- Rapidly growing in Grid Energy Storage. Primary choice for 2-4hr duration. They are growing into 8hr market also.
- Several technical advantages
 - High cycle life
 - Long calendar life
 - High round-trip energy efficiency
 - High energy and power density
 - Scalable from small kW/kWh to multi-MW/MWh energy storage systems
- Rapidly growing manufacturing capacity driven by the needs of the transportation sector
 - Large number of new Gigafactories for EV battery production provide scale and cost reductions
- Pace of Li-ion BESS deployments accelerating
 - Engineering becoming standardized
 - Projects are bankable

Li-ion Batteries



- The most dominant technology up to 4hr, as the costs are going down, they are becoming competitive at 8-10hrs also.
- They support a wide range of duty cycles with good RTE.
- Cost and safety are major concerns.
- **Different flavors of Li-ion batteries: LFP** (Lithium Iron Phosphate), **NMC** (Lithium Nickel Manganese Cobalt), **NCA** (Lithium Nickel Cobalt Aluminum Oxide), **LMO** (Lithium ion Manganese Oxide), **LCO** (Lithium ion Cobalt Oxide), **LTO** (Lithium Titanate Oxide)
- **LFP** is most preferred for grid scale applications. Slightly lower energy density compared to others, but less prone to thermal runaway and uses low cost raw materials.
- Current EV batteries, Energy density ~ 250 Wh/Kg.
- In the near future with improvements in Anode (Si anode) and Cell manufacturing >300 Wh/Kg possible.
- With increasing energy density, safety continues to be a significant concern
- Solid state Li ion batteries are still in the early stages development

Li-ion technology choices

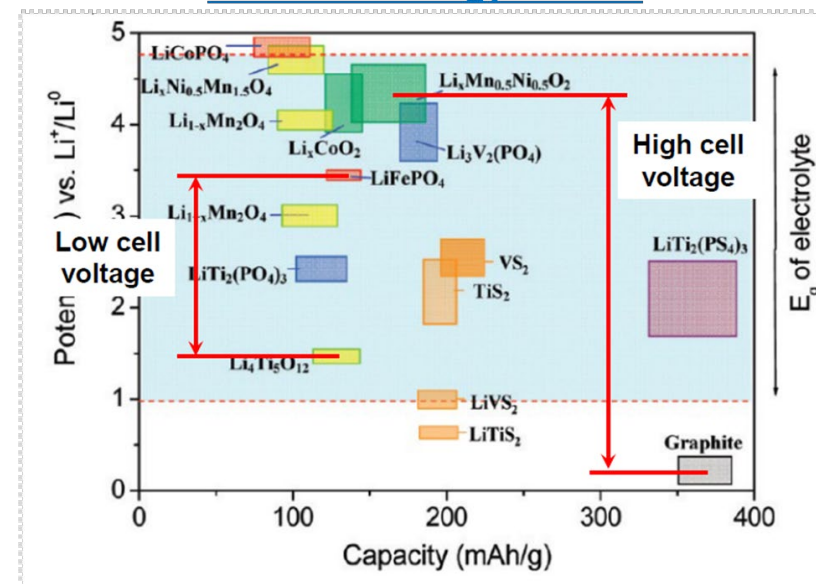

Tesla Megapacks, Moss Landing

Li-ion Technologies - Comparison



Range of technologies offered

- Tradeoffs in safety and other characteristics

Many manufacturers offer blends of materials

- Fine-tuning of product capabilities
- More difficult to fit into generalized comparisons

Batteries for EVs primarily based on variations of NMC

- Effort is to reduce the amount of Co and Ni (reduce cost)

LFP has lower cost and improved safety

- EV manufacturers in China are increasing using LFP
- Integrators of grid storage systems moving towards LFP

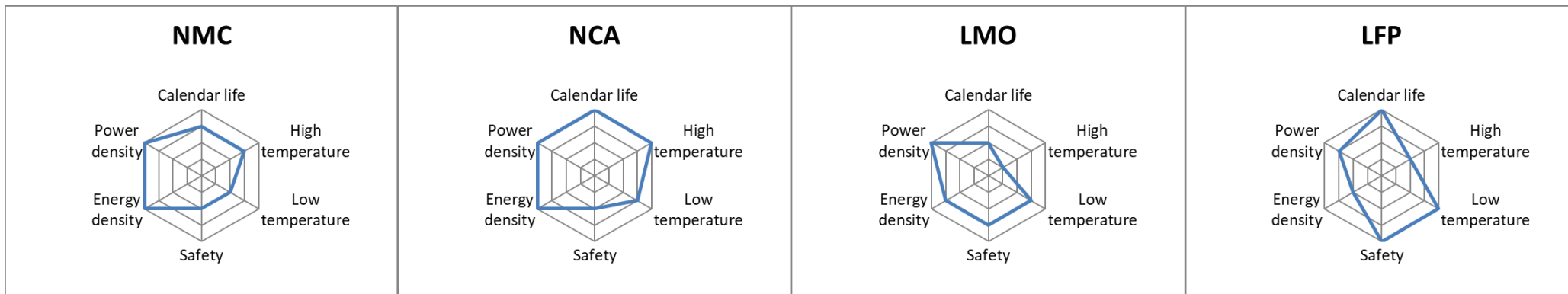

Higher Energy Density
High Power Rating



Lower Energy Density
Lower Cost, Increased Safety

Cell and System Design: Ensuring Safety



Thermal runaway is primary concern for Li-ion

- Energy released during thermal runaway varies greatly by material type
- LFP material has very low heat release
- LCO, NCA are more energetic
- NMC heat release varies by composition

Avoiding module-level propagation (**module design**)

- Avoid heat propagation from a cell in thermal runaway
- Air gap, Thermal insulation
- Phase-change material, Liquid coolant
- Management of vented gas
- In some cases, secondary fire suppression

Layered approach to safety management: BMS, EMS (**system design**)

- Measurement and detection
- Cell balancing
- Battery Management Systems
- Energy Management Systems
- Alarm management

Communications must be properly integrated with host system

- Cyber security and data integrity significant for larger EV and Grid BESS
- Codes and Standards are important

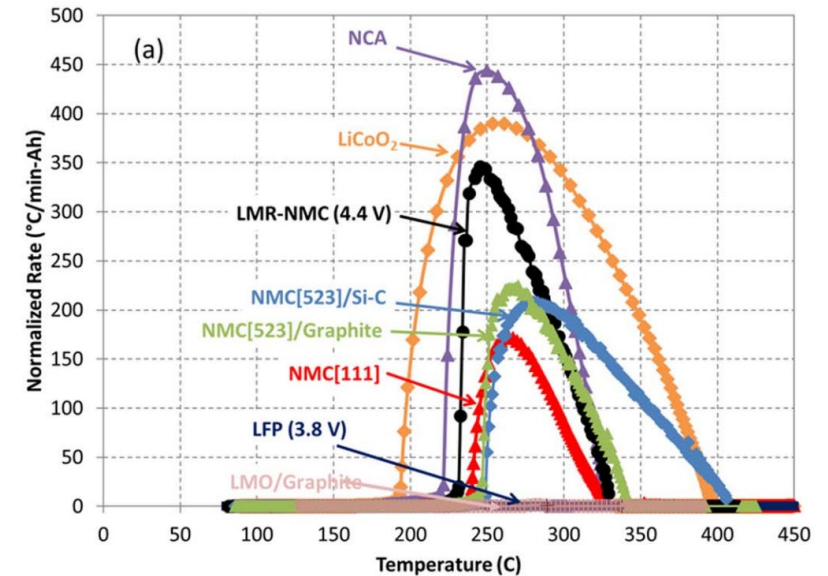

Lamb et al. J. Electrochem. Soc. 2021, 168, 060516.

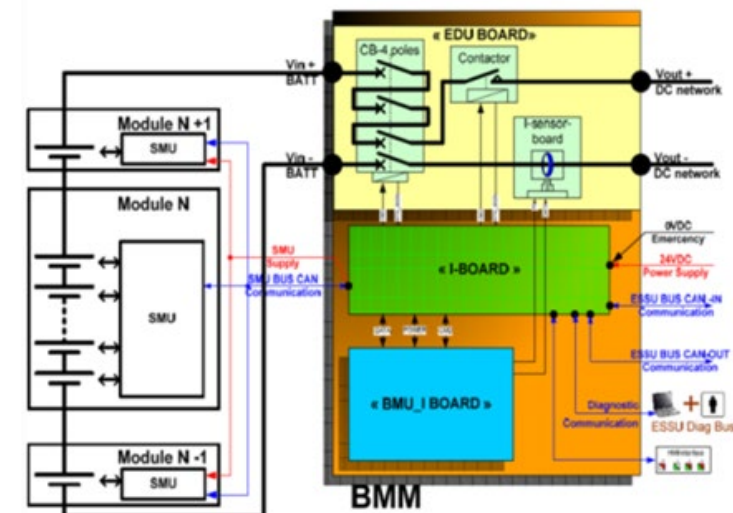

Source: Jim McDowall, SAFT Batteries

Engineering Battery Energy Storage Systems



- Integration costs are significant to meet safety and performance requirements
- Performance of battery energy storage systems are not solely dependent on the cell itself, but in the systems and integration level
 - System-level integration modules, e.g., BMS, PCS, are crucial for the performance, safety, and reliability

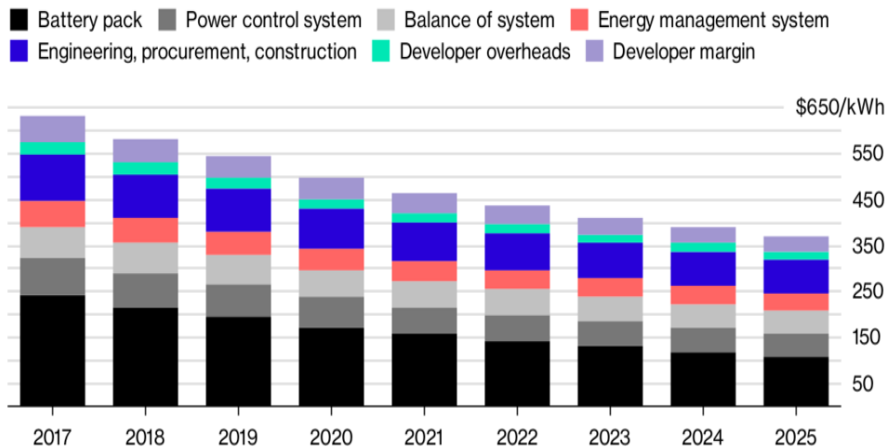

Note: Benchmark numbers for a 1MW/1MWh project
Source: Bloomberg New Energy Finance (BNEF)

Bloomberg

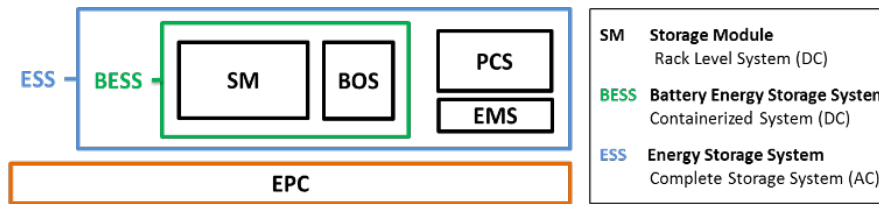

Storage Module (SM)	Balance of System (BOS)	Power Conversion System (PCS)	Energy Management System (EMS)	Engineering Procurement & Construction (EPC)
Racking Frame / Cabinet	Container	Bi-directional Inverter	Application Library	Project Management
Local Protection (Breakers)	Electrical Distribution & Control	Electrical Protection	Economic Optimization	Engineering Studies / Permitting
Rack Management System	Fire Suppression	Connection to Transformer	Distributed Asset Integration	Site Preparation / Construction
Battery Management System	HVAC / Thermal Management		Data Logging	Foundation / Mounting
Battery Module			Communication	Commissioning

Various components are required for system-level integration of batteries for safety, performance, and compliance.



Cell

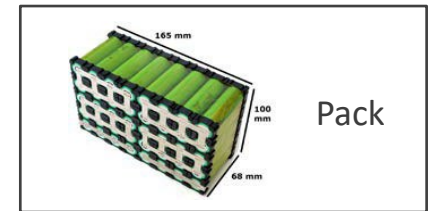
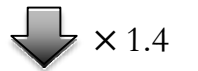

Pack

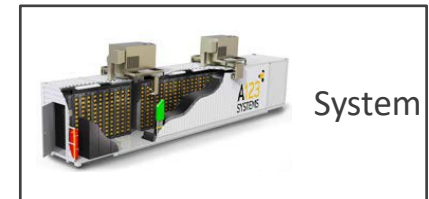
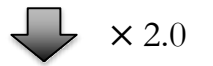

System

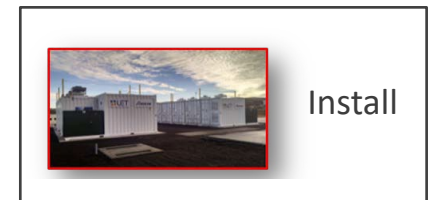
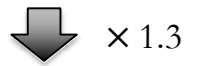

Install

Integration costs increase as cell → battery → Storage System. For example, doubling in cost, <\$100/kWh battery leads to \$350-\$400/kWh at the system level.

Standards to Ensure Energy Storage Systems Safety



Ensuring safety of battery storage systems remains a major concern
Need significant advances at materials, engineering and systems level

- 4 Built Environment**
 International Codes – IFC, IRC, IBC
 IEEE – C2, SCC 18, SCC 21
 NFPA 5000, NFPA 1, ISA
- 3 Installation / Application**
 NFPA 855, NFPA 70, IEEE C2, IEEE
 1635/ASHRAE 21, IEEE P1578,
 FM Global 5-33, UL 9540A, NECA 416
- 2 Energy Storage Systems**
 UL 9540, MESA
 ASME TES-1, NECA
 NFPA 791
- 1 System Components**
 UL 1973, UL 1974, UL 810A, UL 1741,
 CSA 22.2 No. 340-201, IEEE 1547, IEEE 1679

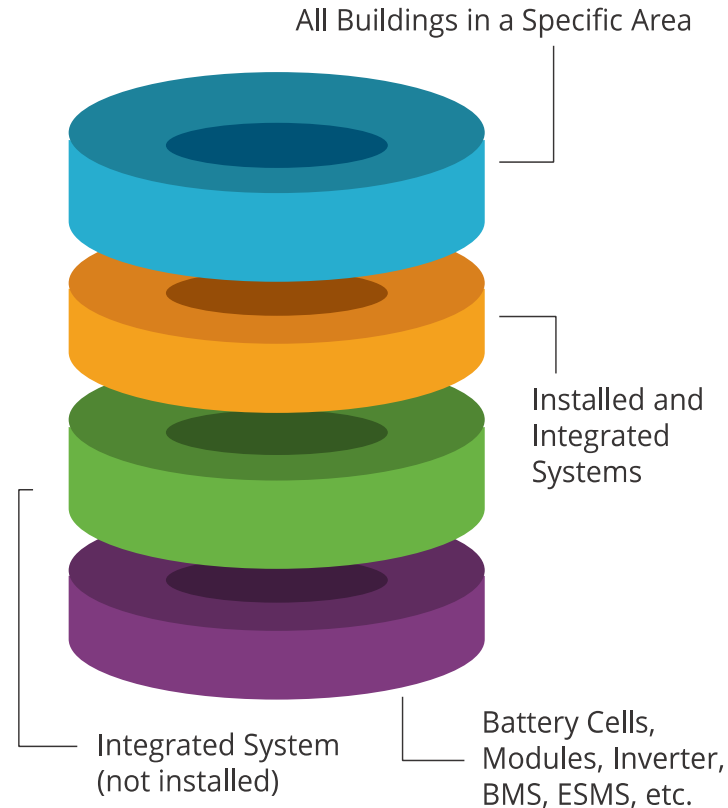

Categories for Energy Storage Codes and Standards

Solid State Li-ion Batteries



- Uses thin film ceramic solid electrolyte separator replacing the liquid electrolyte and the polymer membrane
- No liquid electrolyte – less flammable material
- Enables the use of Li metal anodes
- Promises higher energy density, better safety.
- Issues are degradation due to interfacial separation between the electrolyte and the electrode, fragility of the ceramic membranes.
- Thermal runaway issues are not fully mitigated. Still in the early development stage.

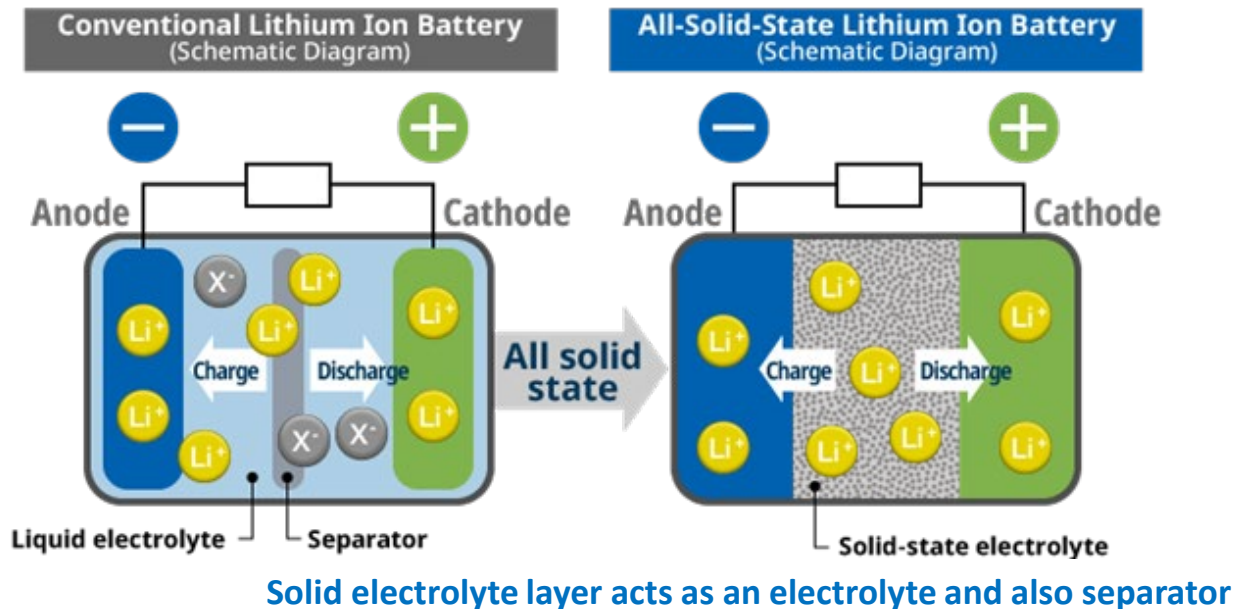

- No liquid electrolyte – less combustible material – battery safety
- Thermal runaway issues are not completely mitigated.
- Oxygen is present in the cathode material.
- Higher Energy Density.
 - Mercedes tested a solid state battery manufactured by Factorial Energy offering 40% more driving range (600 miles/charge feasible).
- **Early stages of commercialization.**

Solid State Li-ion Batteries – Key Challenges

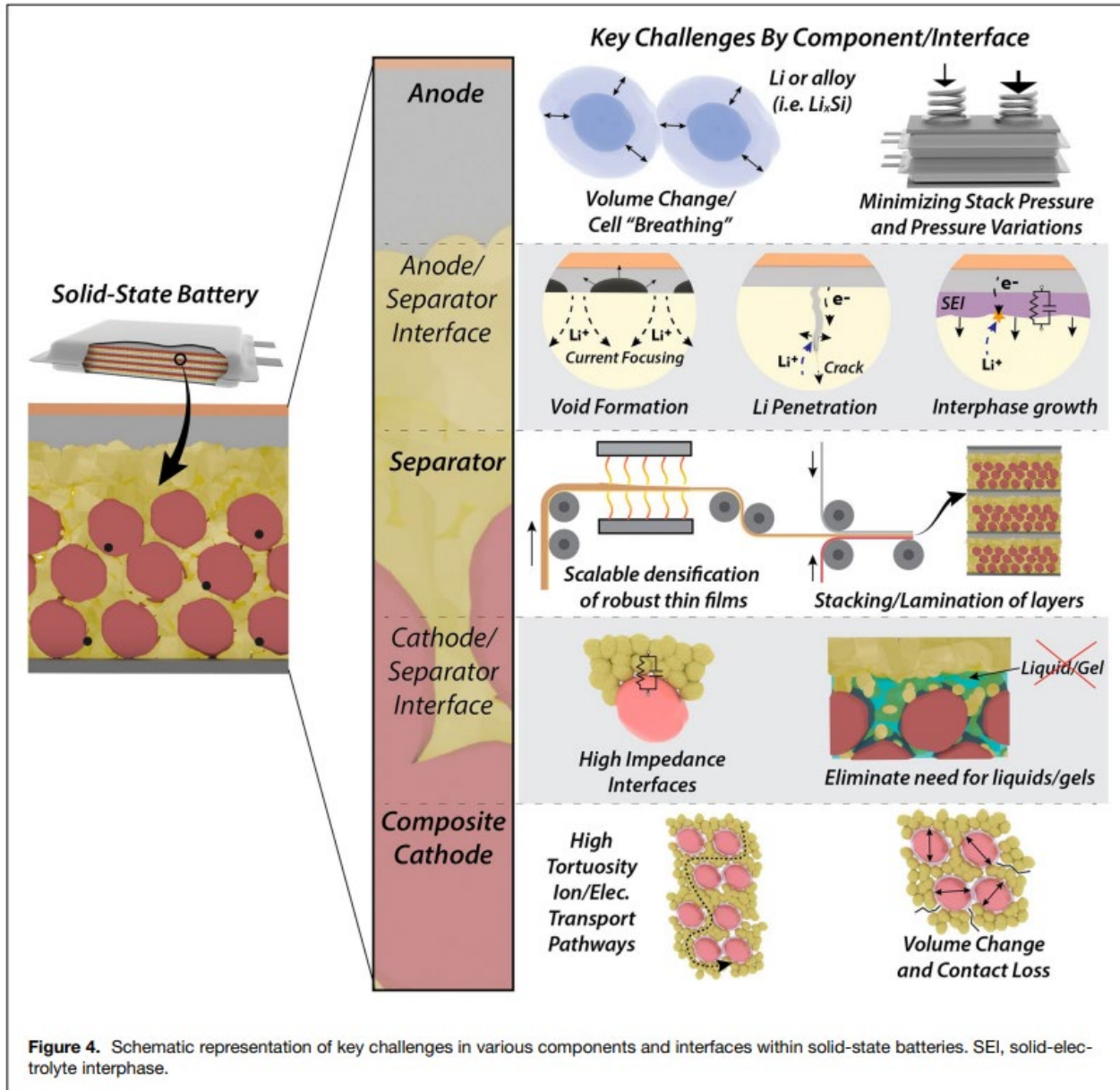

- Lot of progress is being made in these areas.
- We expect to see Solid state batteries soon in few early applications.
- High energy density is the main attraction:
 - Drones
 - Robots
 - EVs
- For Stationary applications, energy density is not very critical. Cost, safety and supply chain issues dominate.

Ref: Kazyak, E., García-Méndez, R. Recent progress and challenges for manufacturing and operating solid-state batteries for electric vehicles. *MRS Bulletin* **49**, 717–729 (2024).

Summary - Li-ion BESS



- Most of the project pipeline for grid energy storage is Li-ion BESS
- Significant growth in manufacturing capacity with a lot of new capacity coming online to support EV market
 - Continued improvements in energy density and reducing cost
 - Rapid cycles of learning, projects bankable
- Entrenched as the technology choice for project developers
- Projects in the 2-4 hour energy markets have become mainstream. Large solar + storage are commercial. 8 hr storage is also starting to take off.
- **LFP** becoming the technology of choice for most grid applications
- Solid state Li ion batteries are still in the early-stages of development

Pb Acid batteries

- In Pb-Acid batteries the active material at + ve electrode is lead oxide, at the -ve electrode it is porous metallic lead. Electrolyte is sulphuric acid.
- During discharge both lead oxide and lead are both converted to Pb sulphate.
- **Vented Lead-Acid (VLA)** dominant form used in automotive starting, lighting and ignition (SLI) batteries.
 - Electrolyte plates are immersed in electrolyte.
 - Gases generated during charging are vented to the atmosphere.
 - Distilled water must be added as needed.

Sealed batteries:

- For convenience and ease of maintenance VLA batteries are being replaced with sealed batteries in many applications.
- **VRLA:** valve regulated lead acid battery. one-way pressure relief valve is added for safety.
- **Gelled electrolyte** type battery: electrolyte is immobilized by gelling (using porous silica particles)
- **AGM type:** electrolyte is fixed in nonwoven silica fiber glass mat (called **Absorptive Glass Mat**)

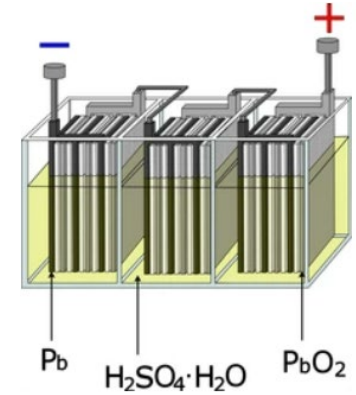

Flooded Lead acid cell schematic

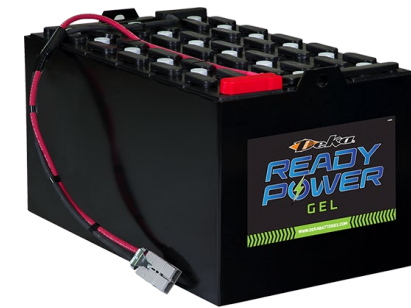

East Penn

VRLA -gel type



EnerSys

Thin plate technology for higher energy density

Lead-Acid Batteries



- Sealed lead-acid
 - Gel and Absorbed Glass Mat (AGM)
 - More temperature dependent
- Advanced Lead Acid Energy Storage
 - Carbon plates significantly improve performance
- Mature technology
- High recycled content
- Used mostly for UPS type applications and indoor storage where there are safety concerns with Li ion batteries.
- Advantages/Drawbacks
 - Low cost/Ubiquitous
 - **Limited life time** (5~15 yrs)/cycle life (500~1000 cycles)
 - **Faster degradation** w/ deep discharge (>50% DoD).
 - **Not competitive with Li ion batteries for grid scale storage**
 - New Pb/C systems > 5,000 cycles.
 - **Low specific energy** (30-50 Wh/kg)
 - Overcharging leads to H₂ evolution.
 - Sulfation from prolonged storage.

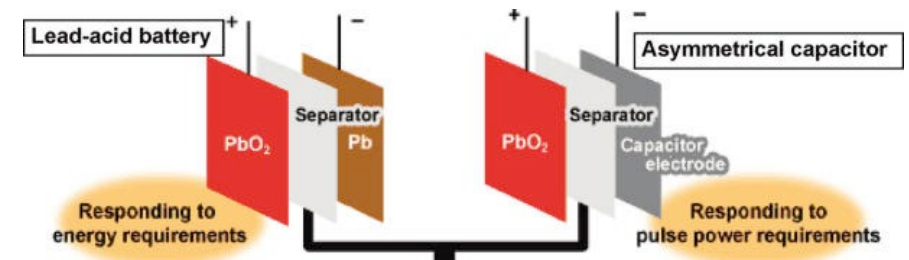
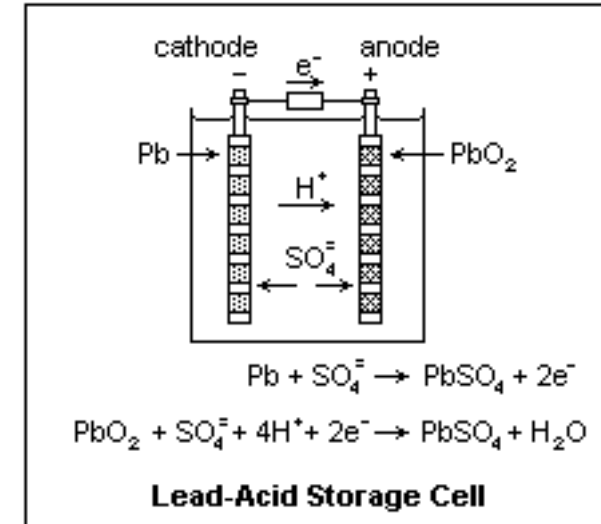

<http://www.ultrabattery.com/>

Overall, Pb acid batteries are not competitive with Li ion batteries for large grid scale storage

Na batteries



■ Sodium ion batteries

- There is a lot of excitement about Na-ion batteries. They use earth abundant materials that are lower in cost and safe (?). They are slowly getting to commercial high volume manufacturing.
- **Different types of Na ion batteries:**
 - **High temperature** (molten Na-S batteries – **NGK, BASF**), Zebra batteries (Na-metal chloride).
 - **Low temperature** (Li ion battery analogues). Several different different chemistries are in development. **Anodes:** Hard carbon, Ti based intercalation oxides, conversion and alloying, **Cathodes:** layered oxides, polyanionic, Prussian blue. **Companies:** Faradion (**acquired**), Natron (**bankrupt**), HiNa, CATL, Farasis, Tiamet, NorthVolt (**bankrupt**), Peak Energy.
 - Less thermal runaway problems. They can be **shipped in zero charge state** (much safer during shipping).
 - Uses **Al current collectors** on both sides (reduces mfg cost).

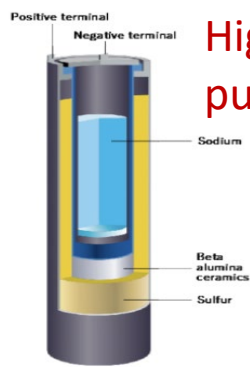
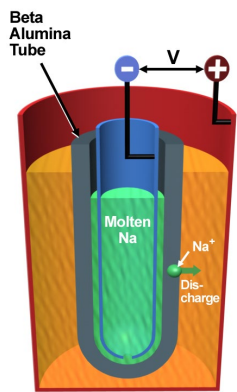

High T: Not much market pull

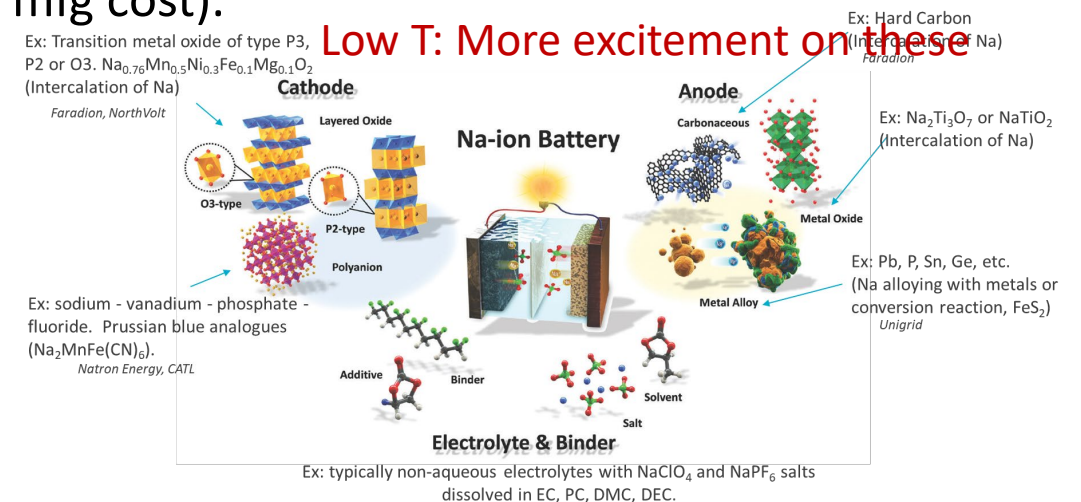
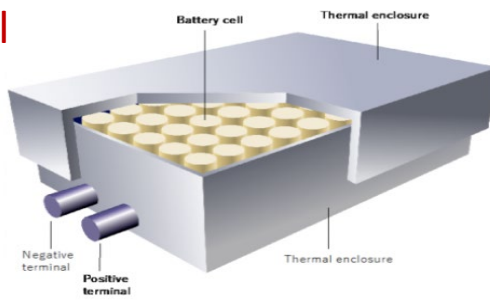

Commercial. RTE ~70%, thermal management, losses

Na-ion batteries



Na-ion batteries (SIB) are very similar to Li-ion batteries (LIB).

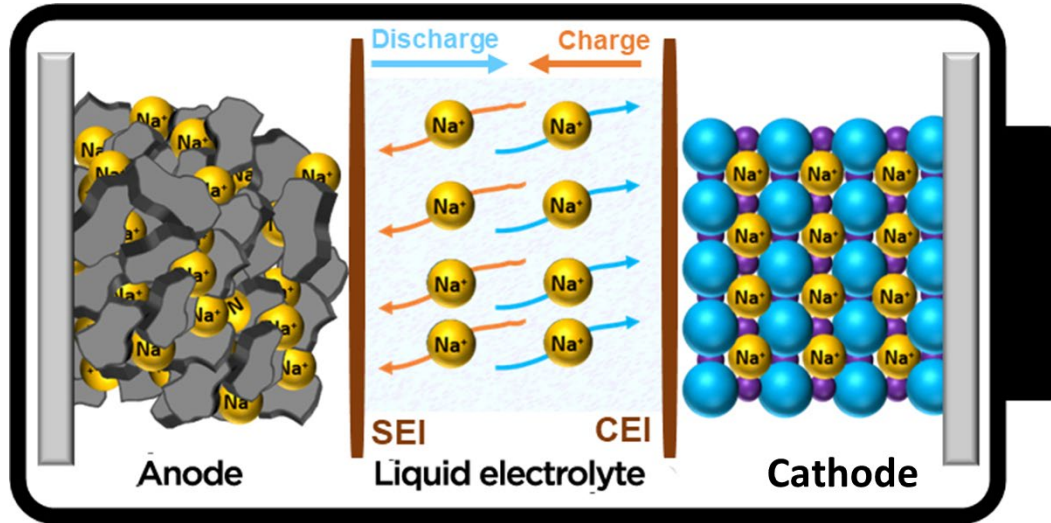

Na ions shuttle between the anode and cathode during charge and discharge very similar to Li ion battery.

Cathodes: Na based material of different types

Anodes: Hard Carbon, intercalation oxides, conversion & alloying

Electrolyte: mostly organic, few aqueous electrolytes

Separator: Polymer membrane very similar to Li ion battery

Current collectors: Al on both sides

- During charging Na ions move from the cathode to anode and the reverse process occurs during discharge.
- In Li ion batteries, Li ions shuttle between graphite anode and layered perovskite type cathode during charge and discharge. Graphite anodes (also Si anodes) used in Li-ion batteries are not a good choice for Na ion batteries.
- Through R&D efforts, suitable stable anode and cathode materials were developed for Na ion batteries and some versions are being commercialized.
- Several Chinese companies such as HiNa, CATL and Farasis, Tiamat in Europe announced mass production plans for commercialization. **In US, Peak Energy is building BESS systems with imported cells from China.**

Sodium ion Battery Performance Comparison



	Lead acid	NiMH	Na-Ion	LFP	NMC
Energy density (Wh/Kg)	30-50	60-120	70-160	90-160	200-250
Nominal Voltage (V)	2	1.25	3.1-3.2	3.2	3.6
Cycle life (80% retention)	200-300	300-1000	>1000	5000	1000-2000
Self discharge [month]	5-10%	15-20%	5%	2-3%	0.5-2.5%
Est. Cost (\$/kWh)	50-100	250	50-80	60-95	90-110
Operating Temp. range (°C)	-20C to 70C	-40C to 50C	-40C to 80C	-20C to 60C	-20C to 60C

- Performance of Na ion batteries are comparable to LFP batteries, their biggest competition.
- Even though Na is much less expensive than Li, the differences are only in the cathode materials and in the current collectors of both batteries, rest of the materials and processing costs would be similar, offering may be 10-20% cost advantage.
- However, due to their wider operating temperature range, BESS systems are simpler (doesn't require expensive air conditioning or liquid cooling, simple fan is sufficient) reducing Op.Ex and may be competitive over lifetime usage.

Sodium-ion batteries summary



- Compared to Li ion batteries, **Na ion batteries are lower in materials cost, and uses earth abundant materials**
 - No Lithium, Cobalt and very low or no Nickel - no supply chain issues
 - Utilizes Aluminum current collectors on both sides
 - Main differences between the two are in cathode materials and current collectors
 - Manufacturing processes are similar. Approx. 10-20% cost advantage over Li-ion batteries
- Lower energy density than NMC batteries, but **performance is comparable to LFP**, their main competition.
- Offers **better low temperature performance** compared to Li ion batteries
 - Wider operating temperature range. Expensive A/C or water cooling systems are not needed, fan cooling is sufficient. Reduces lifetime Op.Ex.
- They can be **charged and discharged faster** than Li ion batteries.
- Na ion batteries can be **stored and transported in zero voltage**. Safe for transportation. Li ion batteries should be stored at some minimum charge.
- Cycle life performance depends on the chemistry. There is a compromise between cycle life and energy density with different chemistries. Currently NFPP polyanion type cathode is preferred.
- **Main challenges are; increasing the cycle life, increasing the energy density and scaling up for high volume manufacturing**. They are slowly reaching high volume commercial manufacturing.

Flow batteries



- Flow Batteries:** Reactants are dissolved in a dilute electrolyte solution and circulated over anode and cathode. It allows the separation of power (battery stack) and energy (storage tank). Easy to scale up for larger system.
- Drawbacks:** Uses dilute solutions, so energy density is low. System complexity is high, requires more ancillaries such as pumps, sensors and control circuits. Needs bipolar stacks, uniform flow fields, ion conducting separator. Some flow batteries requires catalyst. Cross-over of species, composition readjustment, and higher self discharge. RTE ~65-75% Not competitive with Li-ion batteries for short duration storage.
- Different types of flow batteries:** few examples, V redox flow battery (**Invinity**), Fe flow battery (**ESS**), Zn-Br flow battery (**RedFlow -bankrupt**), Zn-Br hybrid battery (**eos**). **CMBlu** –organic flow battery, uses a solid mediator to increase the energy density.

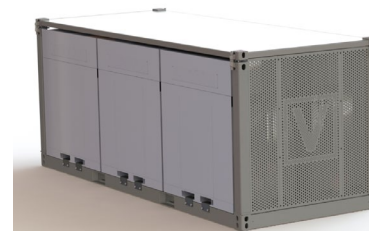
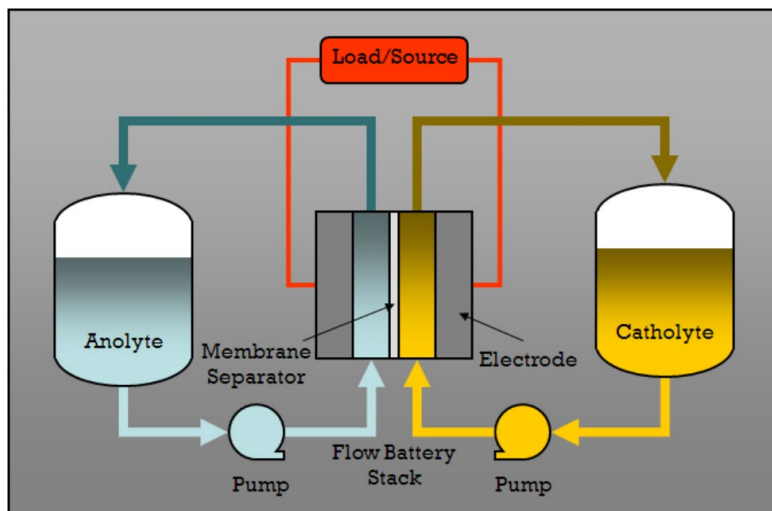

Invinity, V redox flow battery

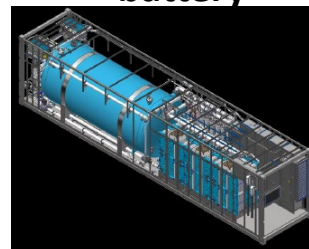

ESS, Iron Flow Battery



CMBlu organic flow battery



eos, Zn-Br Hybrid battery



Red Flow, Zn-Br flow

Flow batteries – Scaling and Grid Applications



- Flow batteries are designed to break the power and energy dependency suffered by Li-ion batteries.
- In flow batteries, power is determined by the battery stack and energy by the size of the electrolyte tank.
- Energy or duration can be increased by increasing the tank size without the need to add more battery stacks. Making it potentially inexpensive for long durations.
- However, because very dilute electrolyte solution is used, the energy density is low. Large tanks are needed.
- System complexity is higher (need pumps, valves, sensors, controls). Electrolytes cross-over requires rebalancing. RTE is less than Li ion batteries (60% versus >90%).
- Self discharge rate is high (easier for liquid electrolyte exchange through the separator). To minimize it, electrolyte solution is drained from the battery and pumped only when needed. Thus, it requires some initiation time. So, they are not suitable for frequency regulation type applications.
- They are suitable for arbitrage, energy time shift type applications.
- Because of their higher cost and low energy density, they are not competitive with Li-ion batteries for short durations <6 hrs. For very long durations >36 hrs, they are not competitive with other competing technologies such as mechanical or thermal storage. Target market appears to be 10-36hr duration.
- Flow battery companies are currently navigating through a very difficult market conditions.
- **Pros:** Non Li, safe – no thermal runaway risk, fewer supply chain concerns. Domestic manufacturing.

Electrochemical – other types

- Other electrochemical batteries:
 - Ni-H₂ Batteries
 - Zn-Mn rechargeable alkaline batteries
 - Ni-Zn

- **Ni-H₂**: Cathode is Ni hydroxide, anode is H₂ gas. During charging H₂ is generated and during discharge H₂ is oxidized producing water. Proven technology for space application. Long cycle life and operating life. Wide operating temperature range. High self discharge rate. Low volumetric energy density (60-100 Wh/L). Uses Ni metal and Pt catalyst. EnerVenue start up out of Stanford, developed a low cost non-precious metal catalyst. Despite the use of H₂ and pressure vessel, the cells are proven safe.
- Good for short duration storage, cost may be concern for LDES.

- **Zn-Mn**: These are very similar to the widely used alkaline primary batteries, but rechargeable. UEP innovation is the development of rechargeable chemistry with high energy density. – Development stage.

- **Ni-Zn**: ZincFive, AEsir technologies – targeting data center applications replacing Pb-Acid batteries.

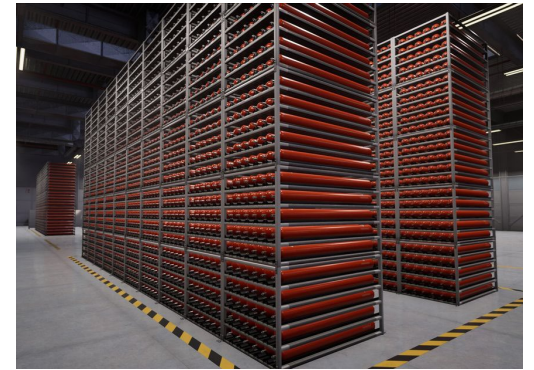

ZincFive



Zinc-based Batteries



Range of alkaline battery chemistries

- Range of battery chemistries incl. NiMH, Ni-Fe, Ni-Cd, Zn-Ni, Zn-MnO₂
- High energy density, mostly aqueous systems (improved safety,) and robust supply chains

Reversibility and cycle life have been the primary technical challenges

Manufacturing not at scale

Zn-MnO₂ ~ 400 Wh/L: Primary, now rechargeable but at lower Wh/L, *commercialized*

Zn-Ni ~ 300 Wh/L: Rechargeable, good power capacity but Ni expensive, *commercialized*

Zn-Air ~ 1400 Wh/L: Many fundamental R&D issues

Zn-Bromine – Performance limitations, need Zn stripping, refreshing time, low energy density, *commercialized*.

Zn-ion similar to Li-ion and Na-ion batteries, early *R&D*

Zn-MnO₂



Zn-Ni



Zn-Air



Zn-Br



Zn-ion



ZĒLOS

Metal air batteries



■ Metal-air Batteries (Fe-air, Zn-air)

- Uses metal anode and air cathode. Since air is supplied by the atmosphere, only one reactant is carried in the cell, thus these batteries can have a higher energy density.
- During discharge the metal is oxidized forming an oxide or hydroxide. It is reduced back to metal during charge
- Zn-air primary batteries are commercialized for few specific applications, such as hearing aid batteries. Rechargeable Zn-air batteries are being developed for Grid scale energy storage application. **Issues: Zn dendrite growth, balance of plant, high self discharge, air cathode limitations, RTE ~60%.**
- Form energy is developing Fe-Air batteries for 160+hr storage application. DOE funded development work on Fe-air batteries at Westinghouse in 1970s. **Issues: low RTE (~40%), balance of plant, air cathode limitations.**

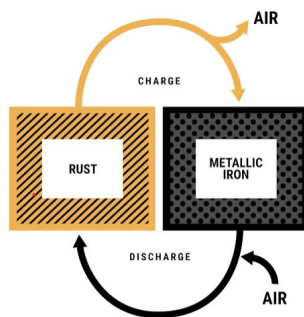

Fe-air battery system schematic

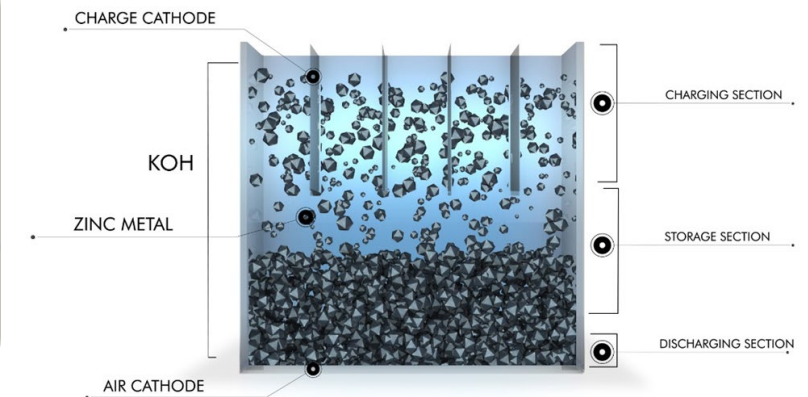
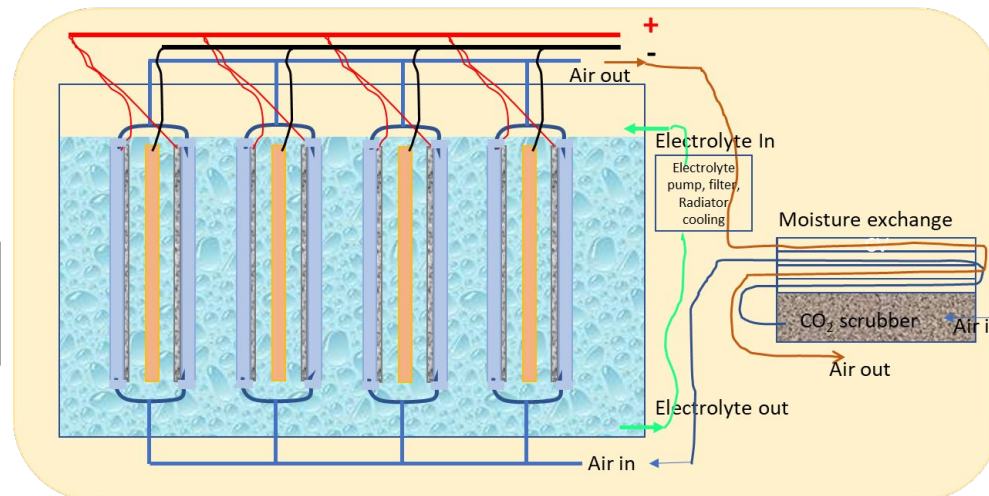

Supercapacitors



- **Difference between batteries and capacitors:**
 - In batteries the energy is stored in bulk chemical reactants, whereas it is stored as surface charge in capacitors.
 - The energy density of batteries is much higher than capacitors
 - In batteries the charge/discharge rates are limited by reaction kinetics and mass transport. These limitations don't apply to capacitors.
 - With supercapacitors, quick charge/discharge is possible. They offer higher power density, superior cycle life and wide operating temperature range, they also have a higher self discharge rate.
 - The output voltage of batteries is relatively constant. It changes linearly with time in supercapacitors.

- **Different types of supercapacitors**
 - EDLC (electric double layer capacitors) – Energy stores in the double layer at the electrode/electrolyte interface - *most common type and commercial.*
 - Psuedocapacitor –involves reversible surface redox reactions for higher capacitance. – *in development.*
 - Hybrid – utilizes both mechanisms for higher performance – *in development.*

- **Applications:**

- Good for “power applications” – frequency response, voltage support etc. Competition – Li-ion batteries.
- A prudent combination of supercapacitor and a battery can be used advantageously to reduce the battery size, extend its life and allows for quick charging.
- Similarly, a fuel cell-supercapacitor hybrid is also ideal in the fuel cell design to reduce the peak power demand and optimize the fuel cell size and increase its efficiency and life.

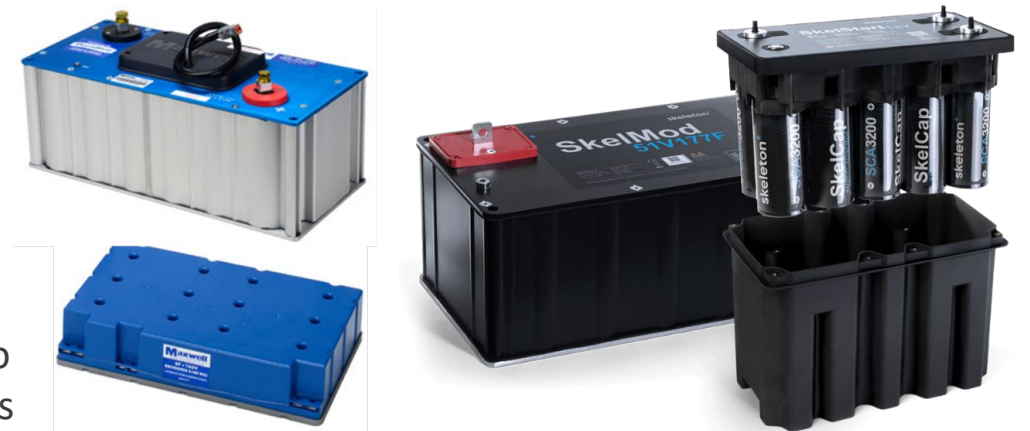

Summary – Electrochemical Storage Technologies



- Most of the energy storage in the US is currently 4hrs or less. Typical batteries on the grid perform ~ 2cycles for day. Frequency Regulation, Arbitrage, Spinning Reserve, Absorb Excess Wind and Solar Generation are the current major application of battery storage.
- Li ion batteries are the most dominant energy storage technology for 4hr duration or below. With high volume manufacturing and reduction in costs they are becoming competitive for 8-10hr storage also. Due to the inherent materials cost limitations, the Li ion battery system costs may not reduce <\$20/kWh needed for wider deployment of LDES on the grid. Also, there are safety concerns with very large battery storage.
- Na ion batteries are in the early stages of development. Promises to be a lower cost and safer option. Right now Cap Ex is expensive compared to Li ion but over the life time they may be competitive due to lower Op.Ex
- High temperature molten Na batteries are commercial, uses low cost raw materials, but the battery systems costs are still expensive and there is no much market pull.
- There are several types of Zn batteries under development. Reversibility and cycle life have been the primary technical challenges. Manufacturing not at scale.
- Flow batteries may be competitive in the 6-10 hr storage duration. Low energy density and higher system costs are concerns for long duration storage.
- In metal –air batteries, Zn-air batteries suffer from zinc dendrite growth and air cathode durability issues. Fe-air batteries suffer from low RTE, air cathode limitations and high self discharge. Form Energy is targeting their batteries for 100+ hr storage for resiliency application with fewer cycles. Currently this is the only battery available 165 hr duration application.

Switching Gears to Non Electrochemical Storage Technologies

Mechanical and Thermal storage technologies

Mechanical Storage



Mechanical Energy Storage

Mechanical Storage (can meet short, medium and long-duration storage needs)

- **Pumped Hydro Storage (PHS)** – **commercial**, currently the largest storage
 - Variations of PHS (Sage Geothermal, Quidnet Energy, Sperra (formerly RCAM)) – R&D or early commercialization stage
- **Gravity based energy storage**
 - Concrete blocks on cranes (Energy Vault), on Railcars (ARES) –R&D or **early commercialization stage**
- **Compressed air energy storage (CAES)**
 - **early commercialization stage**
 - Adiabatic compressed air (A-CAES)- **Hydrostore**,
 - Diabatic compressed air (D-CAES)
 - Variations – liquefied air, compressed CO₂ - **CO₂ Dome**
- **Flywheels** (**commercial** - suitable for short duration storage)

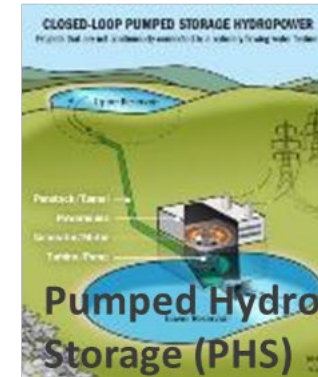

Mechanical Energy Storage



- There are several different types of mechanical energy storage systems, such as flywheels, compressed air or gas, gravity storage (moving rocks or boulders up and down under gravity) and pumped hydro storage.
- In general, these systems are capital intensive and are designed for 10-36 + hr storage.
- **Flywheels**, because of their fast response characteristic, they found early application in frequency regulation market.
- However, these are difficult to scale for energy applications, they tend to get expensive, occupies more space and safety issues. Even for short duration applications, they are facing considerable challenge from the Li ion batteries.
- **Gravity storage** involving moving large rocks up and down on cranes or on a railroad are proposed. They suffer from high capital cost, low energy density and rate limitations. They are still in the early demonstrations stage.
- **Pumped Hydro Storage (PHS)** is currently the predominant storage technology worldwide. They can meet all grid applications. They are capital intensive, location dependent, and permitting processes are long. In the US there are few closed loop PHS projects are in the pipeline.

Pumped Hydro Storage (PHS)

- **Mature technology.** Good for 4-24 hr duration. RTE: 75-85%.
- Power capacities range from 100's of MW to several GW
- It can serve a wide range of grid storage applications
- Currently > 90% of US energy storage is PHS.
- Long lifetime: 50-60 years
- Capital investment is high; storage cost is low. Operation and maintenance costs are also low.

Disadvantages:

- Geographic constraints.
- Long permitting process.
- Higher capital investment.
- Very few new investments. But older systems are getting refurbished to increase operating life.

Few new proposed projects:

- Goldendale Energy storage project (1.2 GW) in Washington state. Received 40 yr license. Redeveloping Brownfields facility –former aluminum smelter facility. Rye development
- Lewis Ridge PHS in Kentucky (Coalfields-to-energy), 266 MW project, Rye
- Swan Lake Energy Storage Project (400 MW) in Oregon, Rye.
- Western Navajo 1 PHS project (500 MW) in Arizona, Rye.
- Carrizo Four Corners PHS project in NM (NM state and Navajo Nation collaboration), 1.5 GW, 70 hr duration.

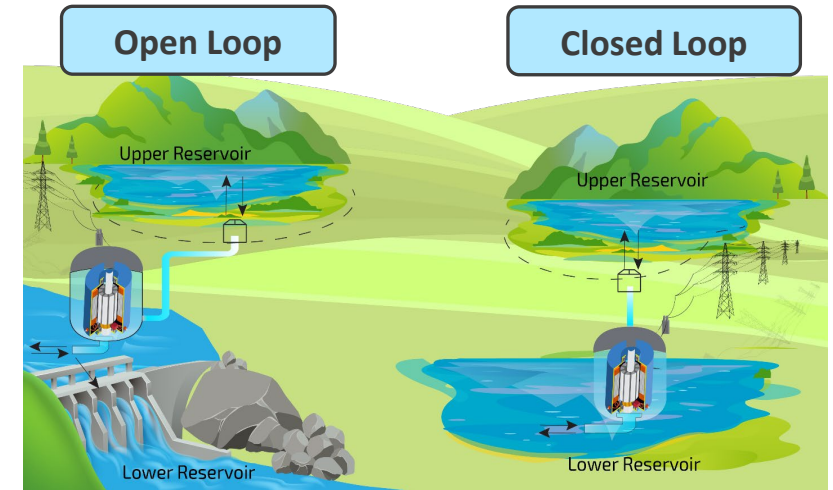

Compressed Air Energy Storage (CAES)

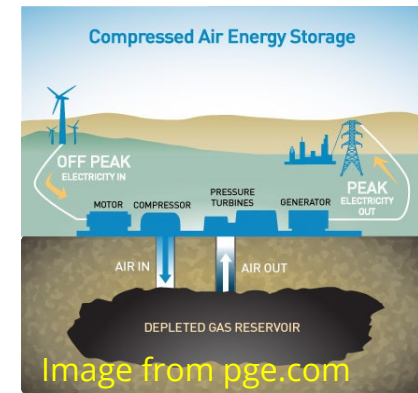

<https://newatlas.com/energy/hydrostor-compressed-air-energy-storage/>



Energydome, <https://energydome.com/>

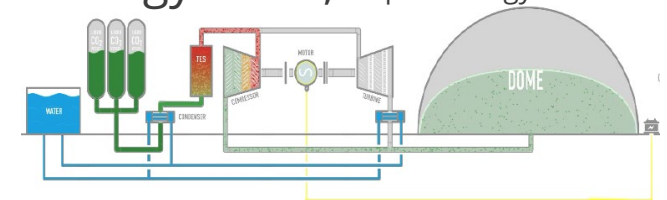

Compressed air (CAES)

- Use electricity to compress air, store it and then re-expand to generate electricity. Compression of air generates heat.
- Two types of CAES: diabatic, adiabatic. In adiabatic the heat of compression is captured for higher efficiency. In diabetic the heat is not captured. Typical RTE: 55-65%.
- Compressed air can be stored above or under ground.
- A-CAES system consists of an air compressor, a storage chamber that holds pressurized air, a thermal energy storage facility and turbine.
- Two old CAES systems in operation, recent proposals are in development stage.
- CAES cannot respond fast, and they are not suitable for power quality voltage and frequency regulation applications.

Variations of CAES: Liquid air energy storage (LAES), CO₂ dome, Storing compressed air or gas in gas pipelines, a combination of compressed air and water head.

Energydome - Compressed CO₂

- Working fluid is CO₂.
- Easier to deal with than air. Clean CO₂ is used. CO₂ has higher molar mass than air, so smaller turbo machinery is needed. Critical temperature is 31C.
- Proof of concept demonstration project done is Italy.
- Uses existing technology. Sacrifices some efficiency for system simplification and reliability.
- Limiting the phase change and not capturing all the heat in the thermodynamic cycle

Energy Dome – Compressed CO₂ storage

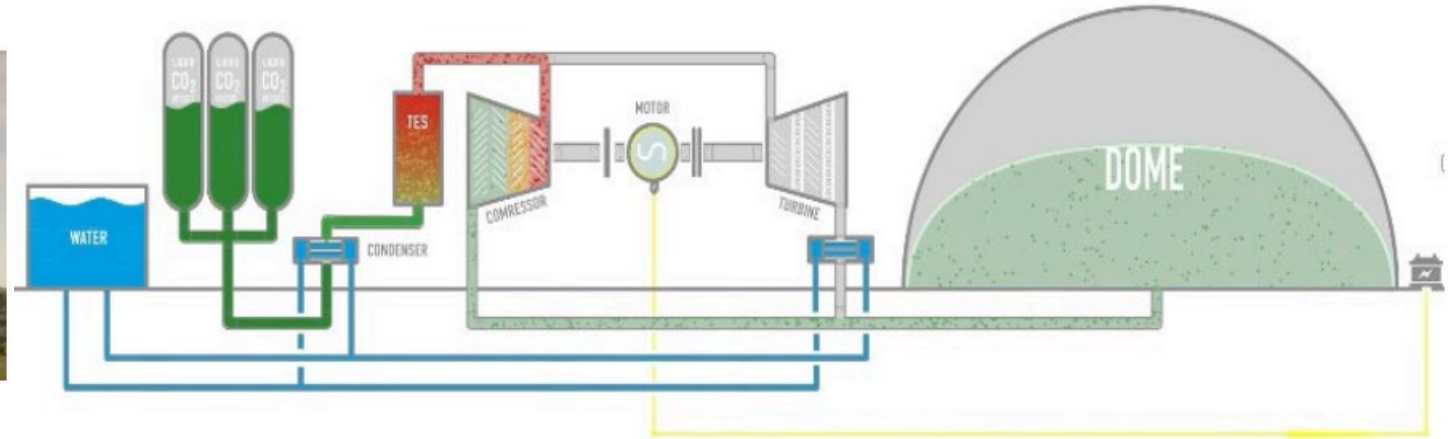
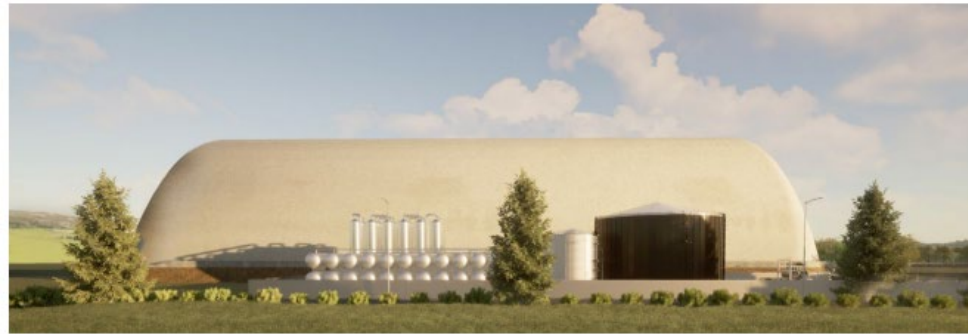

- 20 MW x 10h Commercial Module - Needs 10 to 12 acres of land (mostly for dome) - Dome height is 45 m (@ 150 ft). Outside rigid dome, inside bladder moves up and down with gas.
- Used all commercially available equipment for a quick demo.
- Working fluid CO₂. It can be stored as a liquid at ambient temp in carbon-steel pressure vessel, no cryogenics or chillers needed, Cleaner fluid, less contaminants, higher molar mass relative to air, so smaller turbo machinery. Not corrosive.
- Not going to supercritical CO₂ and eliminated the cold storage for simplicity.
- Development started on CO2B Version 3.0, unit with larger turbine/compressor and higher efficiency (Pilot plant V1.0, Commercial Plant V2.0).
- Capex: \$225-250/kWh, RT 75%, 30+ yr lifetime

3 main states

- 1 Charging**
 - CO₂ withdrawn from atmospheric gasholder (Dome), and compressed by inter-refrigerated compressor
 - Heat generated from compression stored into Thermal Energy Storage System (TES)
 - CO₂ is condensed into liquid state
- 2 Idle**
 - Liquid CO₂ stored at ambient temperature in CO₂ vessels
- 3 Discharging**
 - Liquid CO₂ is evaporated and heated by recovering heat from TES
 - Reheated CO₂ expands in turbine, returning power to the grid
 - Gaseous CO₂ is stored in Dome at ambient temperature and pressure without emissions to atmosphere

Proof of concept demonstrated. Low energy density. Need to understand the scale up issues, operating costs, self discharge losses and RTE.

Mechanical Energy Storage – Hydrostor

- Proposing a 4GWh project in CA. Got approval to start the project but not started yet.

Hydrostor Energy Storage System

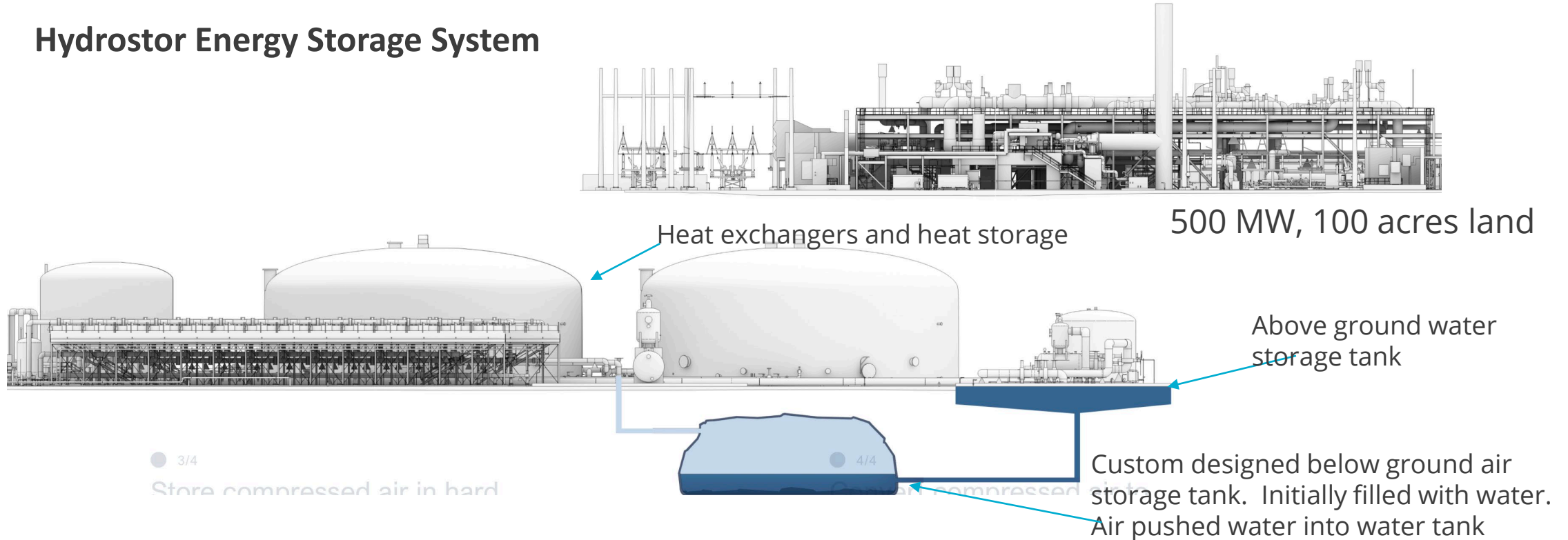

For charging, compressed air is stored in custom designed underground caverns filled with water. Compressed air displaces the water into an above-ground reservoir. During discharge the water head is used to maintain constant air pressure to the turbine, maintaining the efficiency of the turbine. The heat of compression is captured for heating the air to the turbine, thus avoiding the use of any fossil fuels for electrical power generation. System is complex.

Still in the very early stages of demonstration

Variations of PHS for energy storage



Quidnet Energy - Geomechanical Pumped Storage – Subsurface Pumped Hydro

How it Works

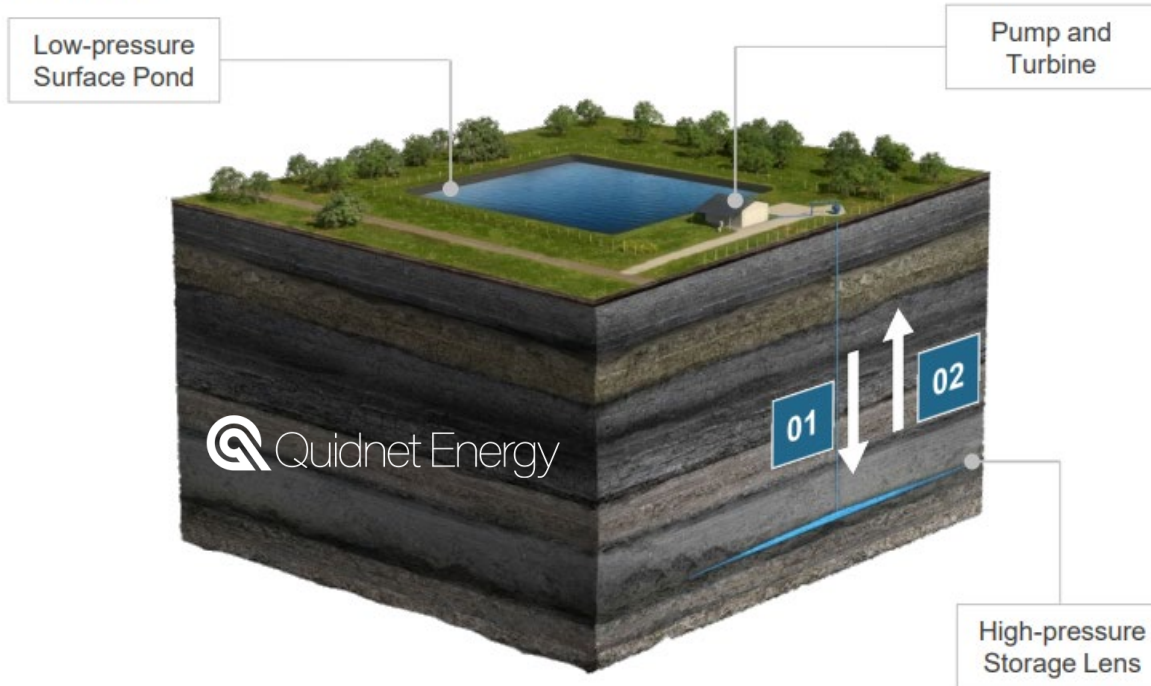

01 Charge. Water pumped down the well into high-pressure storage lens

02 Discharge. High-pressure water flows up the well to drive a turbine

Storage Process

- Pump water from a pond down a well into a body of rock.
- The well is closed, keeping the energy stored under pressure between rock layers for as long as needed.
- When electricity is needed, the well is opened to let the pressurized water pass through a turbine to generate electricity, and return to the pond ready for the next cycle.

1-10 MW systems,
10+ hour modules

Proof of concept stage

Sage Geosystems – pressure geothermal system



Sage Geosystems CEO Cindy Taff, shown second from right, stands with her team at the Texas test site. (Sage Geosystems)



Water drives a pair of turbines at the Starr County test site. (Sage Geosystems)

- Pump water into underground geological fracture between rocks (similar to fracking for oil wells).
- Store water under pressure – **charge**
- For **discharge** – release water – run a Pelton turbine and generator.
- They don't discharge completely or charge fully to keep the rock fissures flexing elastically. It is like breathing.
- Ability to control the discharge rate. Efficiency 70-75%
- Demonstration project done in TX with San Miguel Electric Cooperative.
- Patterned with Ormat, a traditional geothermal energy company.
- **Promising technology and company to watch**

Underwater Pumped Hydro (Sperra - formerly RCAM Technologies)



Subsea storage solution integrates with offshore energy generation to provide firm, steady power

Spheres buried 100-2000 m deep on sea bed

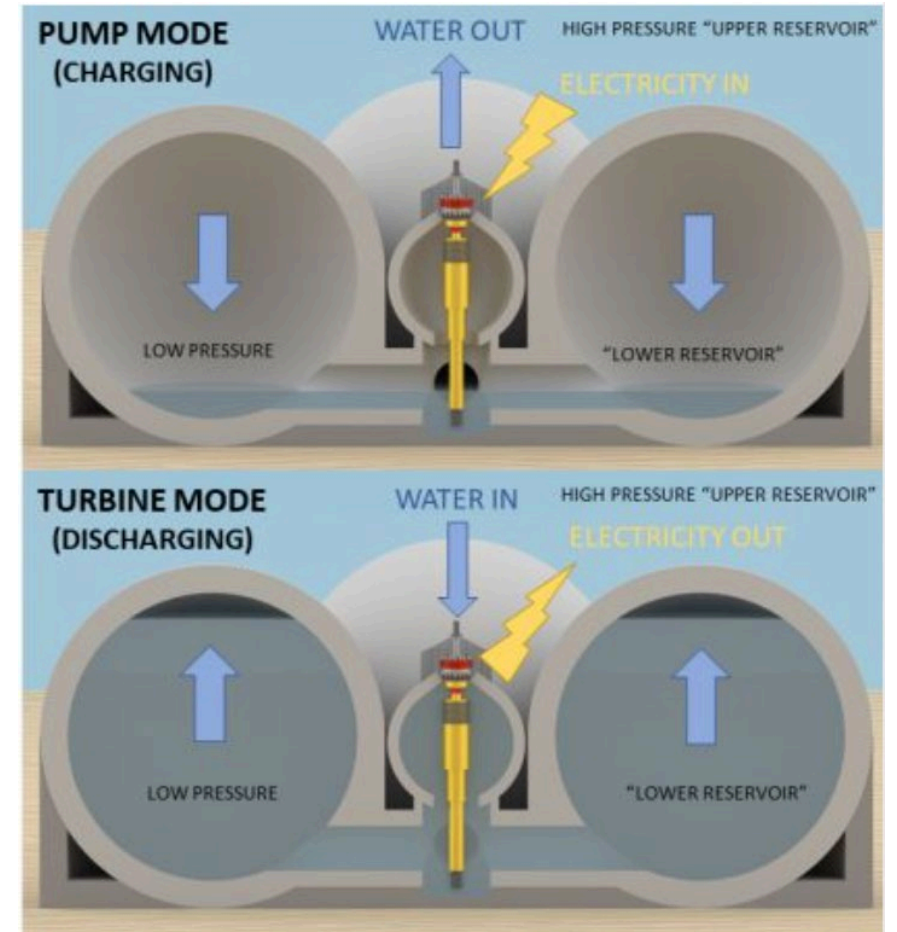

Nominally, three 30-m diameter spheres installed in 700-m water and a 5-MW pump/turbine module has a storage capacity of 60 MWh (12 hours). Increasing the spheres to 8 per pump/turbine provides 32 hours or 160 MWh of energy storage.

Targeting offshore generation to place storage close to generation. Proof of concept stage.

Thermal Storage

- **Convert electrical energy into heat – store heat – convert heat into electrical energy.**
- Thermal storage is more suitable for long duration storage.
- More economical in larger scale. Surface area/volume ratio works better to minimize heat losses.
- It is economical if thermal storage is placed near a facility that can use thermal energy (example: industrial heat or process heat).
- Thermal energy can be stored in three forms: Sensible heat, latent heat (phase change) and chemical reaction.
- **Different variations:**
 - Molten salt thermal storage. – *more mature*
 - Ceramic particle storage media. – *early R&D*
 - Fixed bed thermal storage. – *early R&D*
 - Heated brick or carbon blocks – *proof of concept stage*
 - Molten metal. – *early R&D*
 - Liquid metal battery. – *proof of concept stage*
 - Liquid air energy storage. – *early R&D*
 - Thermochemical – *proof of concept stage*

Thermal Energy Storage



Concentrated Solar Thermal Storage

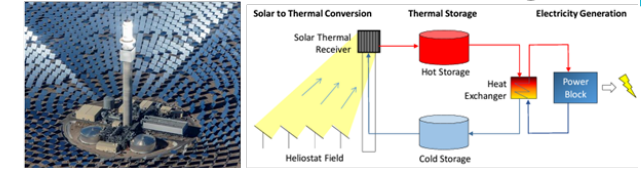

Antora, Thermal Storage

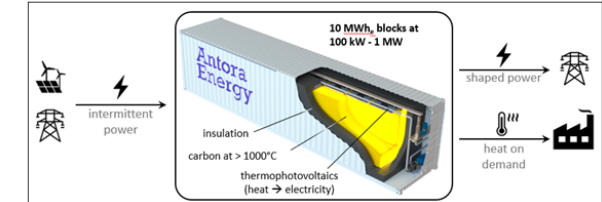

The Rondo Heat Battery

Low-cost, zero-emission industrial heat and power.

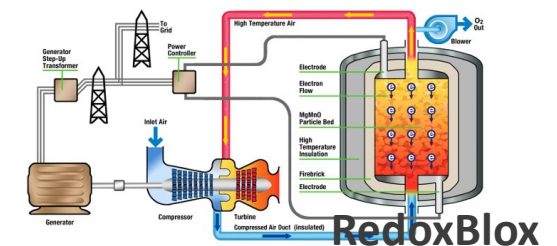
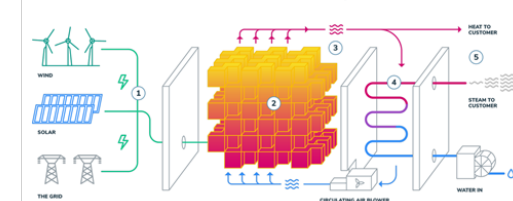

Thermal Energy Storage



Convert into Heat *Different methods*

Compress a
working fluid: air,
N₂, Ar, CO₂ (Malta,
CO₂ dome)

Resistive heating with
different types of heating
elements

- Graphite (Antora)
- Metal/ceramic (Rondo)

**Resistive heating plus
Chemical reaction**
(oxidation, reduction
reactions to increase
energy density)
(RedoxBlox)

Capture and Store Heat

Capture heat through a
heat exchanger (HEX) and
transfer heat to a storage
medium

Store heat

- molten salt (Malta)
- Packed bed (Siemens
Gamesa, CO₂ dome)

HEX

Convert into Electricity *Similar to traditional power plants*

Transfer heat to a working
fluid: gas, air or steam

Use heat in
industrial
processes

Run a turbine
to generate
electric power

**Electrical
energy out**

Cold storage

Another method

TPV
Thermo Photo Voltaic
(Antora)

Direct conversion of
heat to electricity

**Electrical
energy in**

Molten Salt Thermal Storage

50



- More developed technology with concentrated solar power.
- Molten salts (e.g., nitrate salts) are the primary storage medium. Salts are heated to high temperatures (e.g., 385 °C to 565 °C)
- Stored energy in salt is then used to heat a medium, such as water to generate steam.
- Nitrate salts are inexpensive (~\$1/kg) but need to be maintained at ~200-300 °C to keep from freezing.
- Other **issues are corrosion. Handling of hot fluids**



Solana Parabolic Trough Solar Project
1.5 GWh_e storage in 6 pairs of hot and cold tanks.

CSP/Storage Examples

Solana Parabolic Trough Solar Project (Arizona)
280MWh_e with 6 hour storage (~1.5GWh_e)

Crescent Dunes Central Receiver Solar Project (Nevada)
125 MWh_e with 10 hours of storage (1.250GWh_e)

Noor I Parabolic Trough Solar Project (Morocco)
160MWh_e with 3 hours of storage (480MWh_e)

Noor III Central Receiver Solar Project (Morocco)
150MWh_e with 7 hours of storage (1GWh_e)

Thermal Storage Examples



MALTA

Proof of concept stage

Molten salt storage



SNL: National Solar Thermal Test Facility (NSTTF)
Research on **molten salt**, **solid particle bed**, fixed bed thermal storage



Siemens-Gamesa, Hamburg, Germany
1000 tons of rock at 750°C. Using steam turbine, generator to produce 24 hour storage at 1.5MW.

Horizontal **rock bed storage** with air heat transfer fluid. RTE ~ 25 %.
Estimates for a larger system consisting of blocks several hundreds of MW each can have an efficiency of ~ 42 %.

Proof of concept stage

Thermal Storage Examples

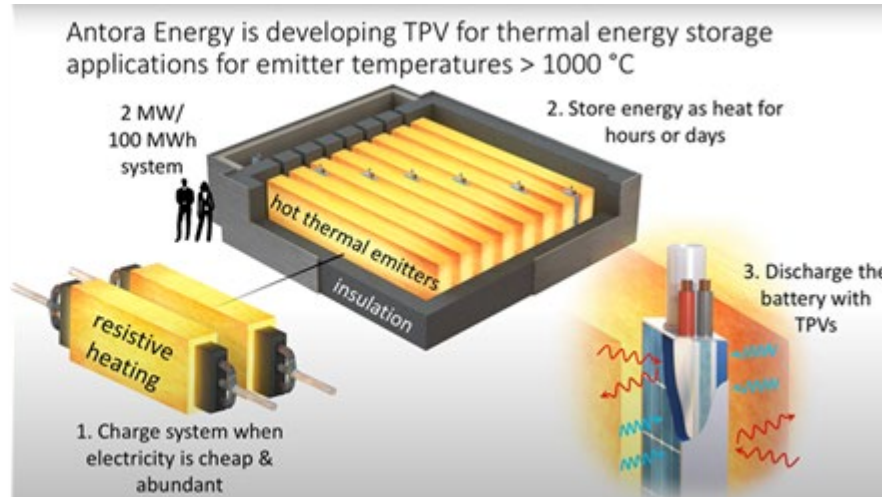

ANTORA

Use electricity to heat graphite blocks. Store thermal energy. Use TPV to convert into electrical power. Initially focused on supplying heat only.

Working on a heat only demonstration project.
Proof of concept stage

The Rondo Heat Battery

Low-cost, zero-emission industrial heat and power.

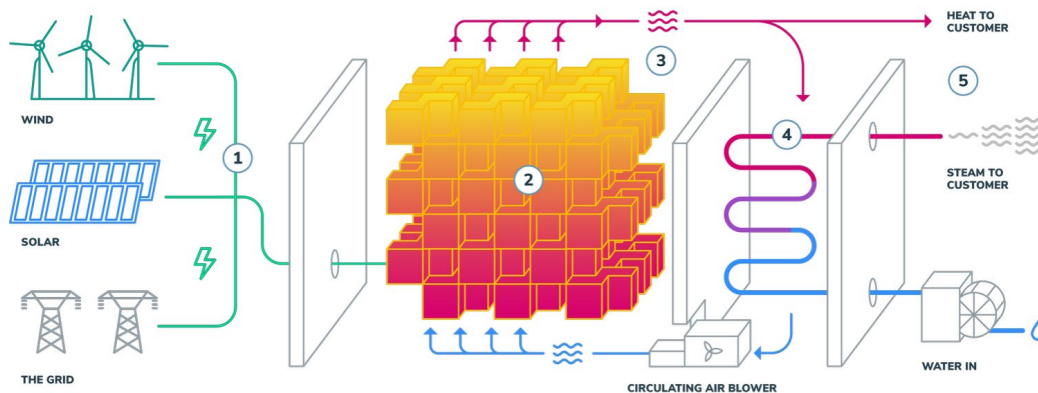

Use electricity to heat ceramic bricks with heaters. Store thermal energy. Air is the working fluid for heat transfer. Initially targeting thermal storage only for industrial use.

Did a heat only demonstration project.
Proof of concept stage

Thermal Energy Storage – Scaling and Grid Applications



- In thermal storage systems, the energy is determined by the size of the thermal storage tank and power by the power generation turbine.
- Power generation is very similar to current thermal power plants (coal, gas or nuclear). For this reason, most companies are focused on the electricity to heat conversion and storage of heat.
- These systems are capital intensive, and they are typically designed for a particular power; meaning that turbine size, heat exchangers and gas flow rates are optimized to generate certain power.
- Operating at a lower power for scaling down can be done, but the system efficiency would be lower. Scaling up power requires adding more turbines and heat exchangers and increases capital investment. For these reasons they are typically designed for a certain power output and prefer to operate under steady state conditions.
- They may be able to meet frequency and voltage regulation applications, but it is not desirable to operate under these conditions. They are good for arbitrage, energy time shift and resiliency applications.
- Thermal energy storage systems are in the early stages of commercialization. They are most efficient and economical when placed close to commercial and industrial facilities that can also use the heat for their operations.

Thermal Storage Summary

- **General issues:**
 - Suitable for long duration storage. Not ideal for short or medium duration (not competitive with batteries).
 - RTE: 55-65% range.
 - Ideal if co-located with a facility where heat can be used for process heat.
 - Compressors, heat exchangers are known technology.
 - Molten salt storage is more developed compared to other concepts.
 - Molten salts are corrosive, difficult to handle hot fluids.
 - With other concepts the issues are; need for good thermal insulation, heat transfer, electrical heating issues, high temperature electric contacts, oxidation, reliability.
 - With TPV: the band gap need to be tuned for thermal radiation. Need a method to remove waste heat from the back end.
 - **Most of these are in development stage, low TRL level.**

Thermal Energy Storage



Concentrated Solar Thermal Storage

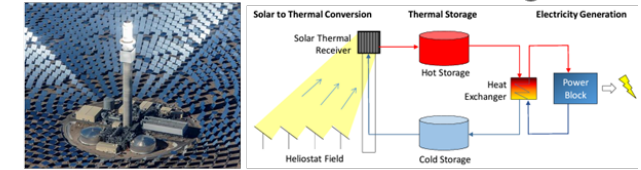

Antora, Thermal Storage

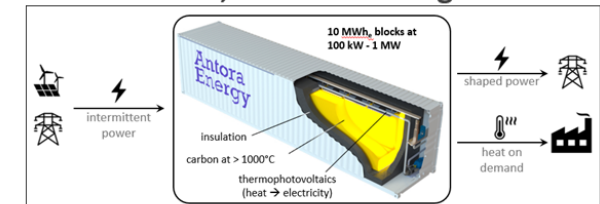

The Rondo Heat Battery

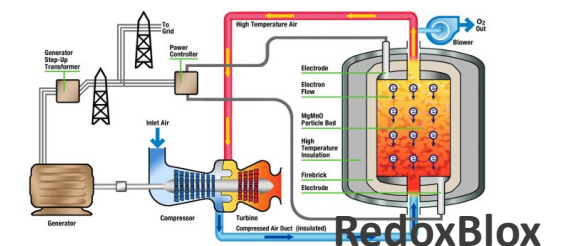
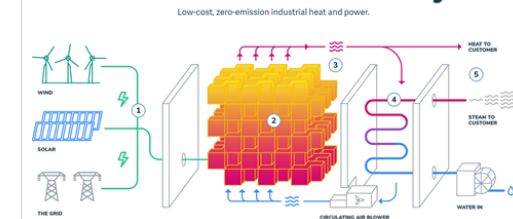

Enhanced Geothermal

- Geothermal system requires **three key elements** to generate electricity: **heat, fluid and permeability** (for water to move freely through the underground rock).
- In many areas, the underground rock is hot but not permeable or fluids present. In those cases, an enhanced geothermal system can be used to create a human made reservoir to tap that heat. Wells are drilled up to 8000 feet.
- In Utah, DOE is sponsoring an ongoing project(FORGE) to develop enhanced geothermal system. DOE goal is to drop the cost of Geo power by 90% by 2035 to \$45/MW
- Currently most Geo thermal power plants operate at low temperature (<200C) with Organic Rankine Cycle. Efficiencies are low.
- Technologies borrowed from Oil and gas industry such as Horizontal drilling and newer drilling technologies to reach higher temperatures are helping to advance the geothermal power.

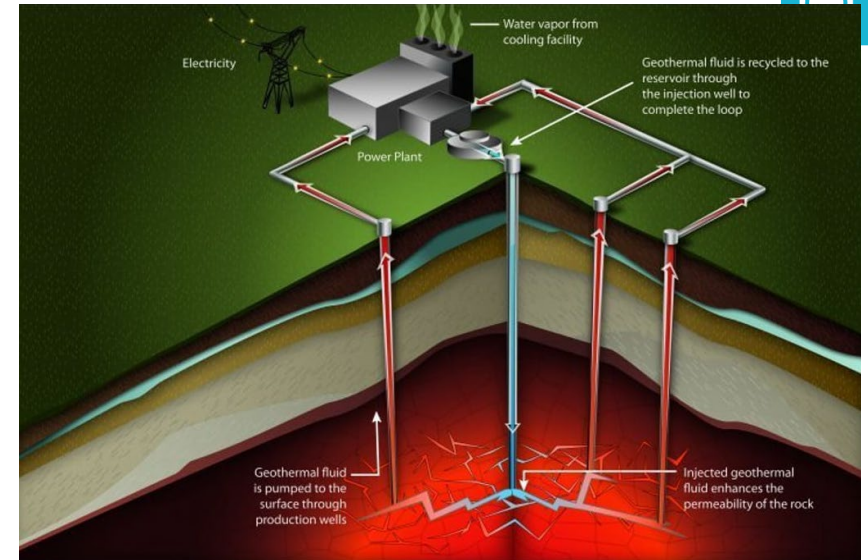

Fervo Energy's 3.5-megawatt enhanced geothermal plant in Nevada. (Google/Fervo)

Chemical Storage - Hydrogen



- **Pros:**
 - Clean fuel. No greenhouse gases. It can be stored, transported and good for **seasonal storage**.
- **Cons:**
 - Low RTE. Flammable gas. difficult to store and transport, leakage or self discharge.
- From electrolysis of water for H₂ generation and electricity conversion using fuel cell, the round trip efficiency estimate: $0.95 \times 0.75 \times 0.95 \times 0.95 \times 0.50 \times 0.95 = \sim 31\%$, which is low.

Process	Efficiency (%)
AC-DC for electrolyzer	95
Electrolysis	75
H ₂ compression	95
H ₂ storage (assume 5% leakage loss)	95
Fuel Cell	50
DC-AC	95
RTE	31
reasonable guess estimates	

- RTE is low, but it is very attractive to produce H₂ from variable resources such as PV or wind, especially when they are asked to curtail.
- Volumetric Energy Density (ED) of H₂ fuel is very low.
- For Comparison:
 - Natural gas ED = 3x H₂ ED (at normal temp and pressure)
 - Oil ED = 1000x Nat. gas = 3000x H₂.
 - It means 1 tanker volume of oil = 1000 tankers of nat. gas and 3000 tankers of H₂.
 - Compression and liquefaction helps little bit in ED, but both (compression and liquefaction) requires energy.

Generation of Hydrogen - Shades of Hydrogen



- There are different colors of hydrogen (industry usage – not real gas color) **depending on how it is produced**. Two major categories are: Blue and Green Hydrogen.
- **Green Hydrogen** is produced from electricity, with **water electrolysis**. The most desirable way to produce H₂.
- Electrolyzers are commercially available. It takes approximately 50-60kWh of electricity to produce 1 kg of H₂. Cost is ~ **\$5/Kg**
- **Blue Hydrogen** is produced from **hydrocarbon fuels** by steam reforming and with **carbon capture**. It is **Grey Hydrogen** without carbon capture. Currently most of the hydrogen is produced this way. Cost is ~**\$2-3/kg**.
 - Unless CO level is very low, H₂ produced this way is not suitable for PEM fuel cells. It can work in solid oxide fuel cells and in combustion turbines to make electricity.
- DOE – “Hydrogen Shot” goal is to reduce the cost of Hydrogen production to \$1/Kg in 1 decade.
- Tax credits passed under IRA (inflation reduction act) for hydrogen generation are significantly curtailed and on accelerated phase out.

Chemical Energy Storage Summary



- **H₂ is a good choice for seasonal storage.**
 - Because of low RTE, it is not ideal for short and medium duration storage.
 - IRA tax credits for hydrogen generation are curtailed and on accelerated phase out.
- **Concerns:**
 - Low RTE (~ 30%) - Electrolysis to electric energy conversion (fuel cell or combustion turbines)
 - Generation of hydrogen - Green H₂ (electrolysis) versus alternatives (reforming hydrocarbons)
 - Need for CO₂ sequestration for H₂ generation from hydrocarbon fuels
 - Storage and transport of H₂
 - Self discharge losses
 - Low volumetric energy density
 - Safety
- **Alternatives:**
 - Convert hydrogen into ammonia or hydrocarbon fuels.
 - Energy intensive processes, but these are convenient fuels for storage, transportation and use.



There are several different types of energy storage technologies:

- For **short duration** storage <6 hrs. **Li-ion batteries** are the **dominant** technology because of its cost competitiveness, technology readiness and commercial availability.
 - For Grid scale storage, the industry is moving towards LFP chemistry because of safety consideration.
 - Safety codes and regulations are in place to ensure battery quality and safety. NFPA 855 (installation), UL 9540 (system certification), and UL 9540A (fire testing).
 - Indoor installations are being discouraged, and the storage is moving outdoors into modular containers spaced a fixed distance apart to avoid large scale fire spreading and thermal runaway concerns.
- **Na ion batteries are emerging technology**, and they may be competitive with Li ion batteries in few years.
- **Pumped Hydro Storage** is currently the **largest grid scale energy storage**. Li ion battery storage is quickly catching up to it.
- For **longer duration storage, there are several different options** such as flow batteries, Zn halide, metal-air, compressed CO₂, compressed air, and thermal storage that may be competitive with Li ion batteries. **Several of these technologies are in the early commercialization stage.**

Thank you for your attention

Questions?

You may reach out Ramesh Koripella, crkorip@sandia.gov
(505)845-7644 or (505) 527-2637 (mobile)

Acknowledgements

This material is based upon work supported by the U.S. Department of Energy,
Office of Electricity (OE), Energy Storage Division.



U.S. DEPARTMENT
of **ENERGY**