

# **SANDIA REPORT**

SAND2012-2090

Unlimited Release

Printed February 2012

## **Utility-Scale Photovoltaic Procedures and Interconnection Requirements**

Abraham Ellis, Benjamin Karlson, and Joseph Williams

Prepared by  
Sandia National Laboratories  
Albuquerque, New Mexico 87185 and Livermore, California 94550

Sandia National Laboratories is a multi-program laboratory managed and operated by Sandia Corporation, a wholly owned subsidiary of Lockheed Martin Corporation, for the U.S. Department of Energy's National Nuclear Security Administration under Contract DE-AC04-94AL85000.

Approved for public release; further dissemination unlimited.

Issued by Sandia National Laboratories, operated for the United States Department of Energy by Sandia Corporation.

**NOTICE:** This report was prepared as an account of work sponsored by an agency of the United States Government. Neither the United States Government, nor any agency thereof, nor any of their employees, nor any of their contractors, subcontractors, or their employees, make any warranty, express or implied, or assume any legal liability or responsibility for the accuracy, completeness, or usefulness of any information, apparatus, product, or process disclosed, or represent that its use would not infringe privately owned rights. Reference herein to any specific commercial product, process, or service by trade name, trademark, manufacturer, or otherwise, does not necessarily constitute or imply its endorsement, recommendation, or favoring by the United States Government, any agency thereof, or any of their contractors or subcontractors. The views and opinions expressed herein do not necessarily state or reflect those of the United States Government, any agency thereof, or any of their contractors.

Printed in the United States of America. This report has been reproduced directly from the best available copy.

Available to DOE and DOE contractors from

U.S. Department of Energy  
Office of Scientific and Technical Information  
P.O. Box 62  
Oak Ridge, TN 37831

Telephone: (865) 576-8401  
Facsimile: (865) 576-5728  
E-Mail: [reports@adonis.osti.gov](mailto:reports@adonis.osti.gov)  
Online ordering: <http://www.osti.gov/bridge>

Available to the public from

U.S. Department of Commerce  
National Technical Information Service  
5285 Port Royal Rd.  
Springfield, VA 22161

Telephone: (800) 553-6847  
Facsimile: (703) 605-6900  
E-Mail: [orders@ntis.fedworld.gov](mailto:orders@ntis.fedworld.gov)  
Online order: <http://www.ntis.gov/help/ordermethods.asp?loc=7-4-0#online>



SAND2012-2090  
Unlimited Release  
Printed February 2012

# Utility-Scale Photovoltaic Procedures and Interconnection Requirements

Abraham Ellis, Ph.D.  
Benjamin Karlson, P.E.  
Joseph Williams, P.E.  
Photovoltaic and Distributed Systems Integration  
Wind Energy Technologies  
Sandia National Laboratories  
P.O. Box 5800  
Albuquerque, New Mexico 87185-1124

## Abstract

This report focuses on the procedures and technical requirements for interconnecting utility-scale photovoltaic (PV) plants, typically greater than 20 MW, to the transmission grid within the United States. The discussion is primarily based on requirements set out by entities such as the Federal Energy Regulatory Commission and the North American Electric Reliability Corporation. The interconnection of utility-scale PV plants is a relatively new concept within the United States, and the requirements for plant performance and interconnection facilities are different from PV's more common application as a distributed resource, especially with respect to generator response to voltage and frequency disturbances. The reasons for growth and the attractiveness of the U.S. PV market are also examined along with the topology of a typical PV plant.



# CONTENTS

1. INTRODUCTION AND OVERVIEW .....	9
1.1. Purpose of Report .....	9
1.2. What is Considered Large-Scale PV?.....	9
1.3. Trend Toward Large-Scale PV Plants .....	10
1.4. Reasons for Growth .....	13
2. APPLICABLE TECHNOLOGIES .....	16
2.1. PV Plant Architecture .....	16
2.2. Types of PV Arrays and Tracking Systems .....	16
2.3. Inverters and Other Balance of Systems .....	17
3. INTERCONNECTION PROCEDURES (FERC LGIP) .....	18
3.1. Application Process and Data Requirements .....	18
3.1.1. Initiating an Interconnection Request .....	19
3.1.2. Interconnection Study Stages and Their Scope .....	20
3.1.3. Queuing.....	22
3.2. Project Data and Modeling Requirements .....	24
3.2.1. Load Flow Data.....	24
3.2.2. Dynamics Data.....	26
4. PLANT PERFORMANCE REQUIREMENTS FOR INTERCONNECTION.....	27
4.1. Voltage and Frequency Tolerance .....	28
4.2. Frequency Tolerance (Under/Over-Frequency).....	29
4.3. Reactive Power Capability and Volt/VAr Control .....	31
4.4. SCADA Integration Requirements .....	31
4.5. Station Configuration and Protection.....	32
4.6. Current Efforts to Update Interconnection Procedures and Standards .....	33
APPENDIX A: SAMPLE PV PLANT DATA SHEET .....	35

## FIGURES

Figure 1. Annual PV system installations by industry segment. ....	10
Figure 2. DeSoto Solar Energy Center, FL.....	11
Figure 3. Planned utility-scale PV projects in the United States. ....	12
Figure 4. Renewable Portfolio Standards by state. ....	13
Figure 5. Annual PV installation by state with solar set-aside. ....	14
Figure 6. PV plant topology.....	16
Figure 7. Example of PV inverter topology.....	17
Figure 8. FERC Standard Large Generator Interconnection Procedure flowchart.....	19
Figure 9. Generic PV plant topology and corresponding single-machine equivalent. ....	25
Figure 10. Proposed NERC PRC-024-1 VRT curve. ....	29
Figure 11. NERC PRC-024 and WECC frequency ride-through curves.....	30
Figure 12. Examples of possible options for generator facility interconnection. ....	32

## TABLES

Table 1. Large-Scale PV Plants in the United States (>20 MW). ....	12
Table 2. WECC ONF Requirement for Generators. ....	30

## NOMENCLATURE

AC	alternating current
CAISO	California Independent System Operator
CdTe	cadmium telluride
c-Si	crystalline silicon
DC	direct current
DG	distributed generation
DOE	Department of Energy
FERC	Federal Energy Regulatory Commission
FRT	Fault Ride-Through
GW	gigawatt
HVDC	High-Voltage Direct Current
IEEE	Institute of Electrical and Electronics Engineers
ISO	Independent System Operator
ITC	Investment Tax Credit
IVGTF	Integration of Variable Generation Task Force
kV	kilovolt
kW	kilowatt
LGIA	Large Generator Interconnection Agreement
LGIP	Large Generator Interconnection Procedures
LVRT	Low-Voltage Ride-Through
MISO	Midwest Independent Transmission System Operator
MVA	mega volt-ampere
MW	megawatt
MWh	megawatt hour
NERC	North American Electric Reliability Corporation
NYISO	New York Independent System Operator
OATT	Open Access Transmission Tariff
ONF	Off-Nominal Frequency
PF	Power Factor
POI	Point of Interconnection
PPA	Purchase Power Agreement

PRC	Protection and Control (NERC Requirements Series)
pu	per unit
PV	Photovoltaic
REC	Renewable Energy Certificate or Renewable Energy Credit
REMTF	Renewable Energy Modeling Task Force
RPS	Renewable Energy Portfolio Standard
RTO	Regional Transmission Organization
SCADA	Supervisory Control and Data Acquisition
SIS	System Impact Study
SPP	Southwest Power Pool
SVC	static var compensator
UFLS	Under-Frequency Load Shedding
VRT	voltage ride-through
WECC	Western Electricity Coordinating Council



# 1. INTRODUCTION AND OVERVIEW

## 1.1. Purpose of Report

The purpose of this report is to provide information to utilities and photovoltaic (PV) developers on the general procedures for interconnection of large-scale PV plants as well as describe the general technical requirements for plant performance. Since 2009 when the first utility-scale PV plant became operational in the United States the interest in utility-scale installations has continued to grow. More and more, large-scale PV has established itself as a viable resource to meet load and to help meet state renewable energy portfolio standards and mandates. This growth in the United States is reflected in the amount of planned utility-scale PV projects that are expected to take the industry from the 300+ megawatts (MW) in operation as of the first quarter 2011 to several gigawatts (GW) within the next few years. Before 2009, all PV plants were connected to the grid at distribution-level voltages. Because of this, experience with PV project interconnection is relatively new for the PV industry. Interconnection at the transmission level does not follow the same principles applicable to distribution systems. This report is intended to help bridge the gap in knowledge as transmission-connected PV becomes mainstream.

## 1.2. What is Considered Large-Scale PV?

PV installations are typically separated into three categories: residential, non-residential, and utility scale. Non-residential PV would include installations at government buildings and retail stores ranging from tens of kilowatts (kW) to several MW, while residential installation would be installed in homeowners premises, typically less than 10 kW. These types of installations are typically on the customer's side of the meter and the energy produced is used predominantly on site. Customer-side generation is under state jurisdiction, and their interconnection is conducted pursuant to state-specific interconnection procedures. The Federal Energy Regulatory Commission (FERC) has issued separate interconnection procedures for large generators, those with nameplate capacity greater than 20 MW, and for small generators, those with nameplate capacity less than or equal to 20 MW.

Applicability of reliability standards is also related to plant size. All commercially available wind turbine generators and PV inverters are well under 20 MW, but the size of the respective plant determines which procedures set of performance standards apply. Existing standards are being modified to clarify application to PV (and wind) generation. For example, the proposed North American Electric Reliability Corporation (NERC) PRC-024-1 standard, which deals with voltage and frequency ride-through, applies to single generating units greater than 20 mega volt-amperes (MVA) and aggregate plants greater than 75 MVA.

Because PV installations have historically been small and distribution-connected, the PV industry is most familiar with the Institute of Electrical and Electronics Engineers (IEEE) 1547, *Standard for Interconnecting Distributed Resources with Electric Power Systems*. IEEE 1547 is applicable for installations up to 10 MVA. Requirements in IEEE 1547 were based on the assumption that energy production would be predominately consumed on site. The specific requirements were tailored to avoid interference of distributed resources with utility grid

operations. At the transmission level, in contrast, interconnection standards are designed to ensure that generation supports grid reliability. It is the purpose of this report to educate the reader on the proper requirements and procedures for interconnecting large-scale PV plants greater than 20 MW per the FERC Large Generation Interconnection Procedures (LGIP).

### 1.3. Trend Toward Large-Scale PV Plants

The price of PV systems has decreased dramatically over the past years, particularly for large PV systems. At the same time, states have strengthened incentives for renewable energy generation. Not surprisingly, this has led to a sharp increase in utility-scale PV installations and proposed PV projects. In 2010, a total of 820 MW of new PV generation was installed in the United States, doubling the 435 MW that was installed in 2009 (utility and non-utility scale). On the basis of installed capacity, the utility-scale PV segment has grown at a faster pace (Figure 1), and this trend is expected to continue in the future.

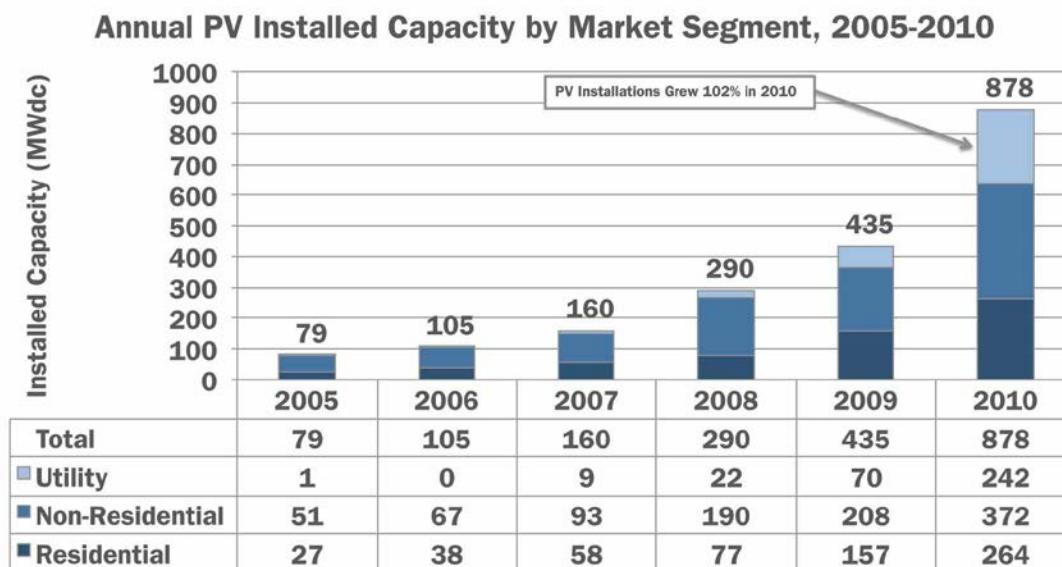

Figure 1. Annual PV system installations by industry segment.<sup>1</sup>

There are three features that make the United States an attractive market for PV installations. The United States has an excellent resource in terms of solar insolation levels, ranging from 3.5 kWh/m<sup>2</sup>/day in the northeast to 8.5 kWh/m<sup>2</sup>/day in the southwest.<sup>2</sup> It is important to note that the regions with the lowest insolation levels in the United States are comparable to those found in Germany, the current global leader in PV installations.

Another reason for sustaining long-term PV growth is the availability of land in the United States, especially in the sparsely populated western states.

<sup>1</sup> Source: SEIA Solar Market Insight, 2010 Year in Review.

<sup>2</sup> National Renewable Energy Laboratory; <http://www.nrel.gov/gis/solar.html>.

Where merely a few years ago in the United States a PV plant over 20 MW did not exist, now installations of that scale are becoming more frequent. In 2009, when the DeSoto Solar Energy Center in Florida was completed (Figure 2), it became the first transmission-connected PV plant in the United States (230 kilovolts [kV]). With a total installed capacity of 25 MW it was then the largest PV plant in the United States. Utility-scale PV plants are typically owned and operated by a third party and sells the electricity to a market or load serving entity through a Purchase Power Agreement (PPA). Table 1 lists the PV plants in the United States that are greater than 20 MW.



*Figure 2. DeSoto Solar Energy Center, FL.<sup>3</sup>*

---

<sup>3</sup> Florida Power and Light, <http://www.fpl.com/environment/solar/desoto.shtml>.

Table 1. Large-Scale PV Plants in the United States (>20 MW).<sup>4</sup>

Name	Size (MW)	Purchasing Utility/ Service Territory	State	In-Service Date
DeSoto Next Generation Solar Energy Center	25	Florida Power & Light Company	FL	2009
FSE Blythe	21	Southern California Edison Co.	CA	2009
Copper Mountain Solar I Project	48	Pacific Gas and Electric Co.	NV	2010
Cimarron I Solar	30.2	Tri-State Generation & Transmission Association Inc.	NM	2010

This trend of PV plant increasing in size is expected to continue in the near future. Figure 3 shows the announced utility-scale PV projects that are under contract (PPA signed) and pre-contract. Of the 6,055 MW currently under a signed contract, 561 MW of utility-scale capacity is expected to come on line in 2011.

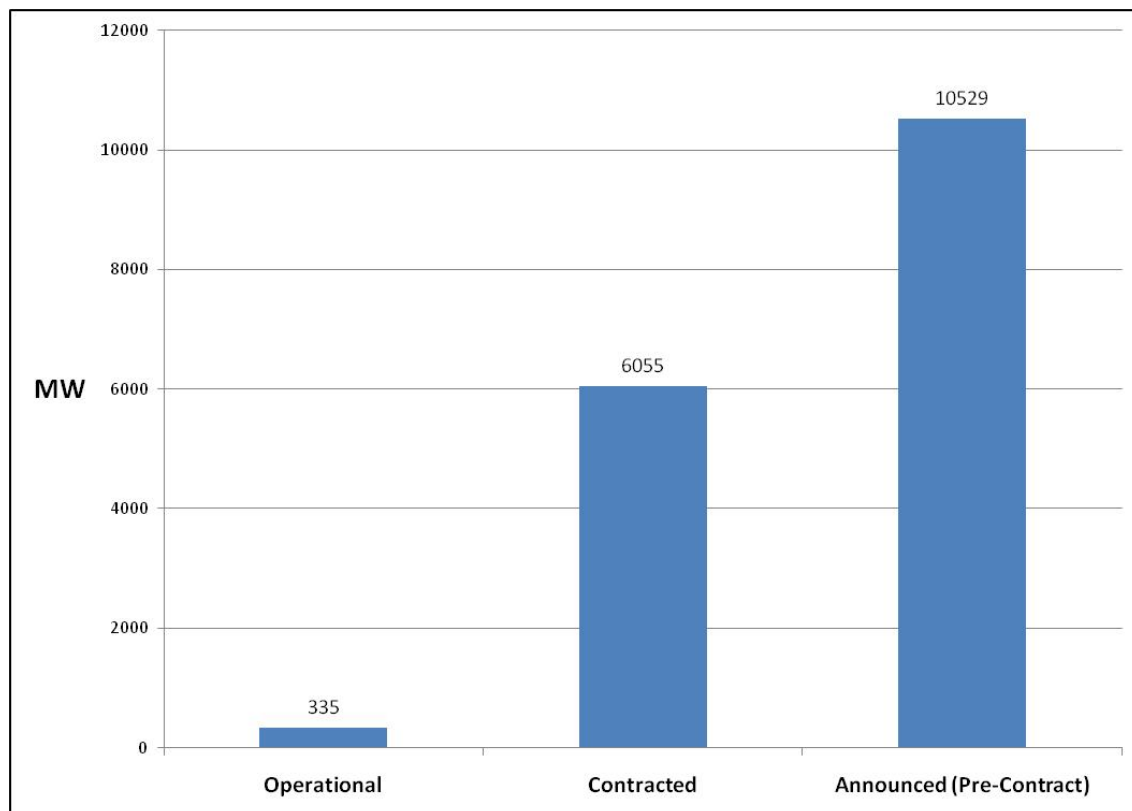

Figure 3. Planned utility-scale PV projects in the United States.<sup>5</sup>

<sup>4</sup> Solar Electric Power Association, <http://www.solarelectricpower.org/>.

<sup>5</sup> As of first Quarter 2011, Source: GTM Research, [www.gtmresearch.com](http://www.gtmresearch.com).

## 1.4. Reasons for Growth

State and Federal policies are key drivers for renewable energy growth in the United States. Top among those are state Renewable Energy Portfolio Standards (RPSs) that require a percentage of a state's electric energy consumption to be generated by renewable energy resources. Also contributing to the additions of PV are Federal tax incentives, state rebate and incentive programs, and voluntary green markets. Below is a summary of a few of these key drivers.

### Renewable Portfolio Standard

State RPSs require utilities to meet a specified percentage of electric energy needs from eligible renewable energy technologies annually. Figure 4 shows a state-by-state breakdown of RPSs in the United States as of September 2011. A total of 16 states plus the District of Columbia currently have set-asides for solar generation. Among the states that have solar provisions, six have additional requirements or incentives for PV systems: Delaware, Illinois, Massachusetts, Nevada, Oregon, and Pennsylvania.

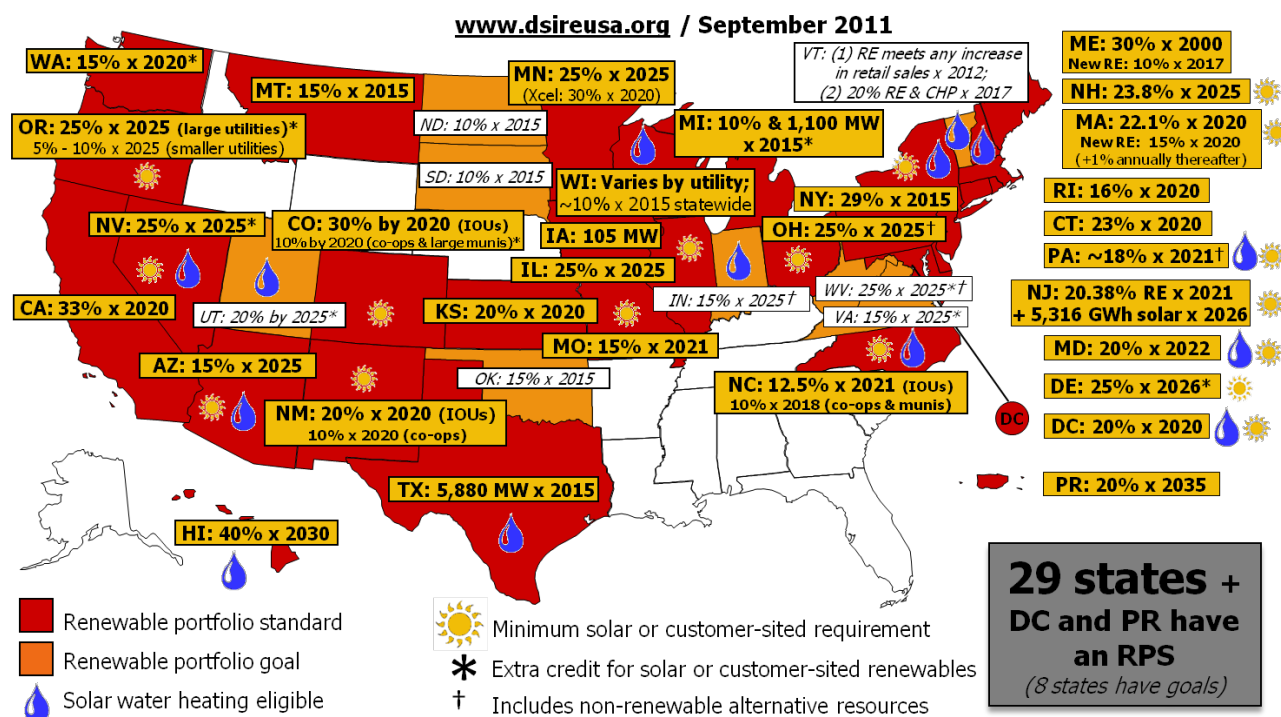

Figure 4. Renewable Portfolio Standards by state.<sup>6</sup>

<sup>6</sup> For more information, <http://www.dsireusa.org/>.



Figure 5 trends the annual installation of grid-tied PV to state with a solar set-aside. The trend indicates that from 2005 through 2009, 65 to 81% of total new installed grid-connected PV in the United States occurred in states with solar set-asides.<sup>7</sup>

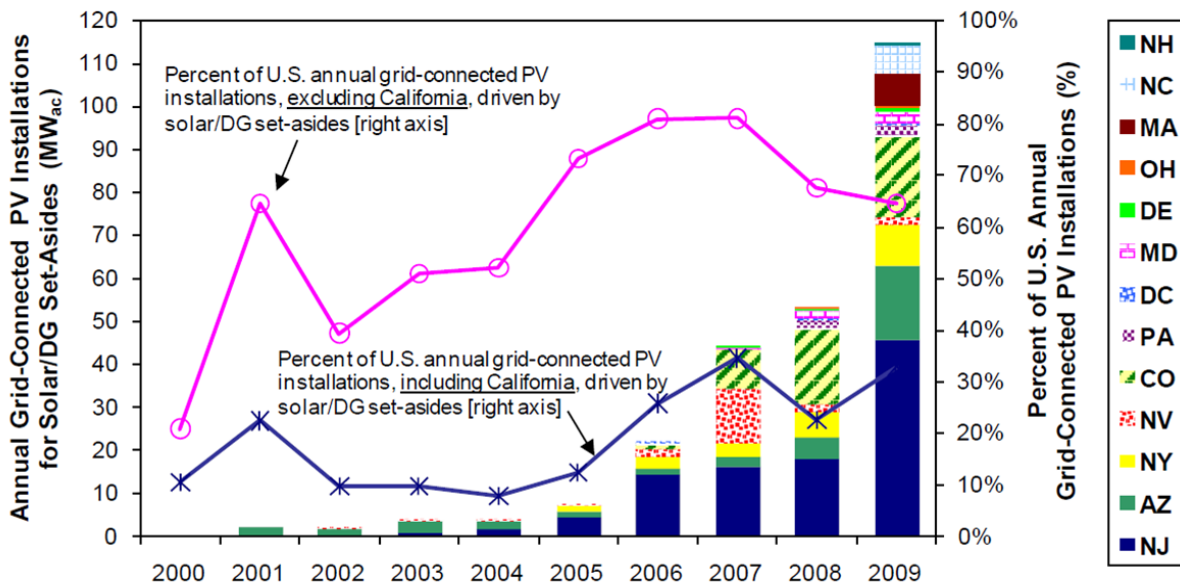

Figure 5. Annual PV installation by state with solar set-aside.

The creation of state RPSs has led to the creation of a market for Renewable Energy Certificates (RECs). A single REC represents the renewable attributes of one megawatt hour (MWh) of electricity production from an eligible renewable energy generation facility. In some states RECs can be purchased by the utility and count toward the RPS mandate. This can provide potential revenue for solar projects in those states that allow RECs and electricity to be unbundled and sold separately.

### Federal Tax Credits

Federal tax incentives applicable to large-scale PV include the Federal Investment Tax Credit (ITC) and a Modified Accelerated Cost Recovery System.<sup>8</sup> Several states also offer investment tax credits for solar installations.

Currently, solar projects receive an ITC equal to 30% of the project's qualifying costs until the end of 2016, at which time the credit will revert to 10%. The credit is realized in the year in which the PV plant begins its commercial operation and is vested over a five-year period. There are also certain limitations on the ITC if it is used in combination with other incentives.

<sup>7</sup> R. Wisner, G. Barbose, and E. Holt, *Supporting Solar Power in Renewables Portfolio Standards: Experience from the United States*.

<sup>8</sup> Production Tax Credit Implemented by IRS Code Section 45. ITC Implemented by IRS Code Section 48.

Section 168 of the Internal Revenue Code provides a Modified Accelerated Cost Recovery system for investments in solar power projects. This section allows projects a five-year, double declining-balance depreciation.

Additional investigation into the various Renewable Portfolio Standards, Renewable Energy Certificate programs, and tax incentives is warranted on a project-to-project basis.<sup>9</sup>

---

<sup>9</sup> For more information regarding tax incentives, see “Financing Non-Residential Photovoltaic Projects: Options and Implications,” M. Bolinger, 2009, and “PTC, ITC, or Cash Grant? An Analysis of the Choice Facing Renewable Power Projects in the United States,” M. Bolinger, R. Wiser, K. Cory, and T. James, 2009.

## 2. APPLICABLE TECHNOLOGIES

### 2.1. PV Plant Architecture

The components of a large-scale PV plant work together to transform the energy from the sun into grid-compatible AC electricity. Figure 6 shows a typical layout of these components.

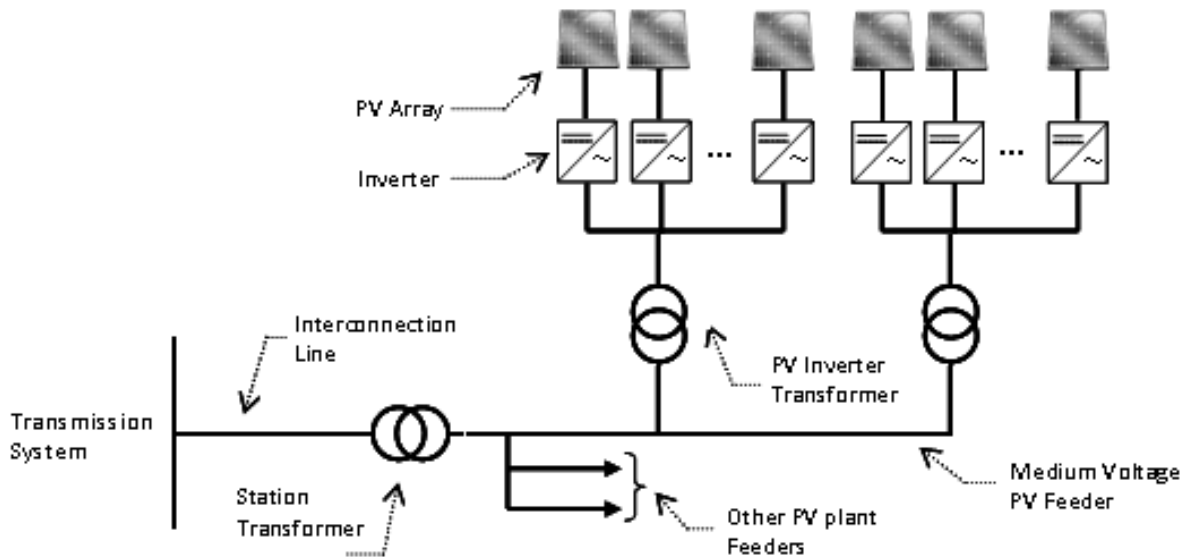

Figure 6. PV plant topology.

The direct current (DC) energy created by the solar arrays is converted to low voltage (200 V to 480 V) AC by the inverters. At this point the voltage is then stepped up to a medium (12.5 kV to 34.5 kV) voltage to more efficiently carry the energy to a single collection point, where the voltage is further stepped up to match the transmission grid. The rest of Section 2 will provide further detail on PV plant components.

### 2.2. Types of PV Arrays and Tracking Systems

Photovoltaic systems use semiconductor cells to convert solar radiation into DC electricity. The three most common types of PV technologies are crystalline silicon (c-Si), thin-film technology, and concentrating PV. Crystalline silicon solar cells are by far the most common technology for the solar cell market today.<sup>10</sup> Current reporting on efficiency of thin-film cells are in the area of 11% whereas c-Si cells come in around 20%.<sup>11</sup> Thin-film technology can also use Si as the semiconductor (usually amorphous Si) but have also used other materials such as cadmium telluride (CdTe).

<sup>10</sup> For more information, see [http://www.eere.energy.gov/basics/renewable\\_energy/photovoltaics.html](http://www.eere.energy.gov/basics/renewable_energy/photovoltaics.html).

<sup>11</sup> B. Kroposki, R. Margolis, and D. Ton; Harnessing the sun, *Power and Energy Magazine, IEEE*, vol. 7, no. 3, pp. 22-33, May-June 2009.



Concentrating PV technologies utilize lenses or mirrors to focus sunlight on a small area of high-efficiency cells. Demonstrations of concentrating PV show large-scale system efficiencies of 25%.<sup>12</sup>

In addition to the semiconductor technology, there are different ways that a system can optimize energy capture. The arrangement and angle of the PV cells can play an important role in the total energy capture of the plant. While it is more common for PV arrays to have fixed mounts, some PV arrays use one-axis tracking systems to enhance energy production. Tracking systems are required for concentrating PV.

### 2.3. Inverters and Other Balance of Systems

Inverters are required to transform the DC output of the solar arrays to alternating current (AC) electricity compatible with the electric grid. A specific configuration for a PV plant’s DC-to-AC converter is shown in Figure 7.

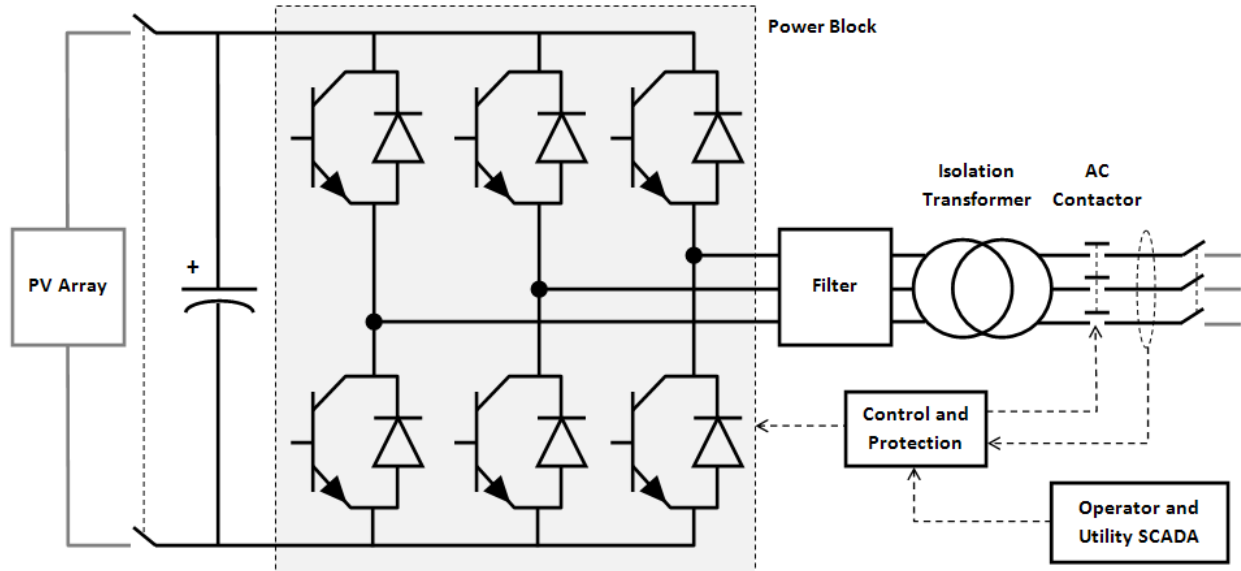

Figure 7. Example of PV inverter topology.

One of the inverter functions is to control the DC voltage to ensure that the PV array operates at maximum power. Inverters also incorporate grid compatibility functions such as anti-islanding, and reactive support. The rating of power converters for large-scale solar plants today is typically 250 kW; however, 1-MW converters are just starting to appear.

<sup>12</sup> S. Kurtz, “Opportunities and Challenges for Development of a Mature Concentrating Photovoltaic Power Industry,” National Renewable Energy Laboratory, 2009.

### 3. INTERCONNECTION PROCEDURES (FERC LGIP)

In general, interconnection of new large-scale generating facilities takes place in accordance with the transmission provider's *pro forma* Open Access Transmission Tariff (OATT) on file with the FERC.<sup>13</sup> FERC Order 2003 sets forth the Standard LGIP for generators greater than 20 MW<sup>14</sup> as well as the Standard Large Generator Interconnection Agreement (LGIA). These documents lay out the responsibilities of the both the transmission provider and the interconnection customer.

This section provides an overview of the FERC Standard LGIP. It should be noted that the following examines the LGIP as of the issuance of FERC Order 2003-C.

#### 3.1. Application Process and Data Requirements

Illustrated in Figure 8 is a flowchart representation of the LGIP used to process interconnection requests. When an interconnection request is made and deemed "perfected" or completed by the transmission provider, the request is entered into the interconnection queue. The transmission provider uses the queue to determine the sequence in which the interconnection request will be studied. Section 3.1.3 has more information on the queue management.

After initiating an interconnection request, a three-step process is used to determine the interconnection costs and construction sequencing: (1) the Interconnection Feasibility Study (Feasibility Study); (2) the Interconnection System Impact Study (SIS); and (3) the Interconnection Facilities Study (Facilities Study). The interconnection customer is obligated to pay the transmission provider a certain deposit for the performance of each study. After completion of the studies, the difference between the deposit and the actual cost incurred will be paid by or refunded to the interconnection customer. The interconnection customer is responsible for providing project data needed for the studies to proceed. The interconnection process concludes with the signing and execution of the LGIA, or a withdrawal of the application.

During the interconnection study process, most proposed projects have not finalized aspects of their design, possibly including the project size. The interconnection procedures allows for modifications of the application to be made at certain junctures during the study process. Such modifications are evaluated by the transmission provider to determine if the change would impact the position on the interconnection queue (see Section 3.1.3).

The purpose of the interconnection studies is to determine the system upgrades necessary to interconnect the proposed project and the associated cost and construction schedule. It should be noted that securing delivery rights entails a separate application and study process not covered in this document. Additional upgrades may be required for delivery service. It should be noted that, in general, interconnection service does not convey delivery service.

---

<sup>13</sup> Standard Large Generator Interconnection Procedures, FERC Order No 2003-C, <http://www.ferc.gov/industries/electric/indus-act/gi/stnd-gen.asp>.

<sup>14</sup> Standardization of Generator Interconnection Agreements and Procedures, FERC Order 2003 <http://www.ferc.gov/whats-new/comm-meet/072303/E-1.pdf>.

## FERC Standard Large Generation Interconnection Procedures

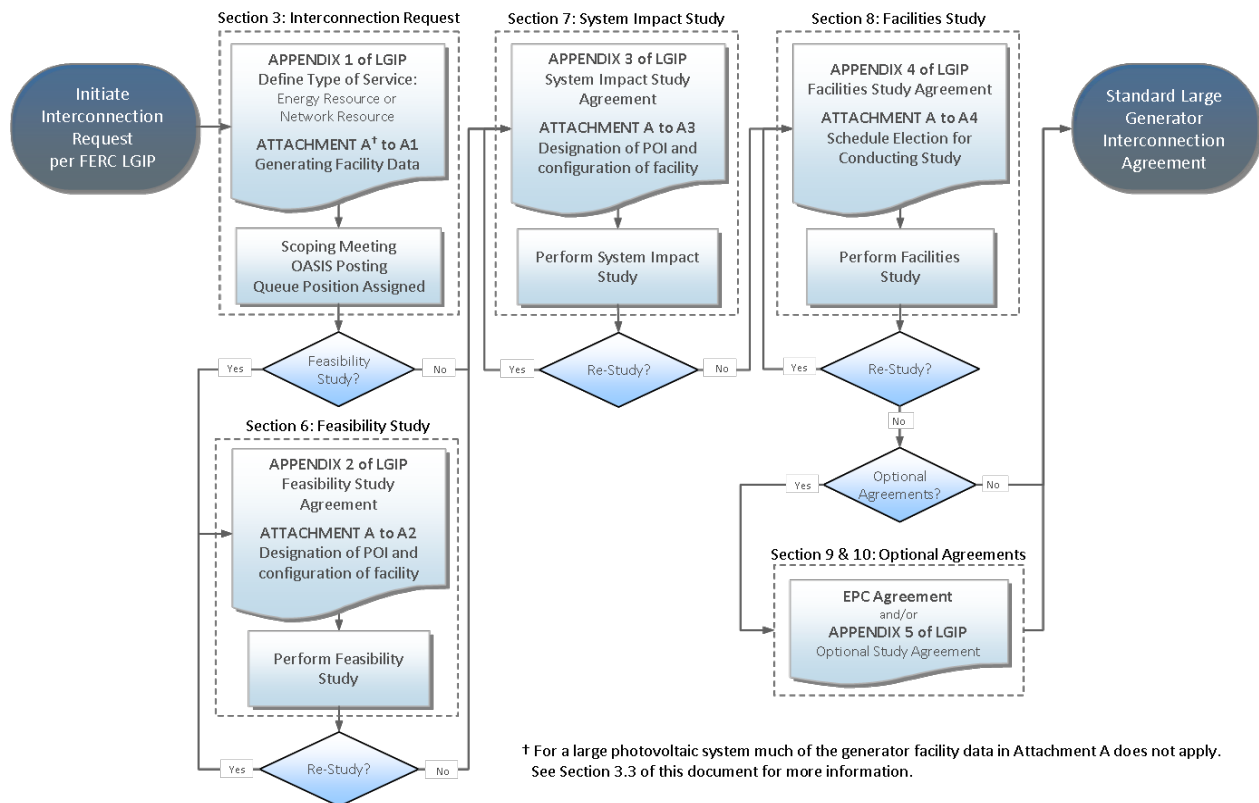

*Figure 8. FERC Standard Large Generator Interconnection Procedure flowchart.*

The interconnection process can be technically complex when it involves multiple proposed projects in the same general location. Sometimes the studies must be conducted in coordination with other transmission providers that may be affected by the proposed interconnection. For these reasons, it can take months or even years for an interconnection request to go through entire interconnection process.

### 3.1.1. Initiating an Interconnection Request

To begin an interconnection request, the interconnection customers must complete the data request per Appendix A to the pro forma OATT and provide a refundable deposit to the transmission provider. The deposit will be applied towards the actual cost of the interconnection study. The data to be provided at the initiation of the interconnection request are the following:

- Type of interconnection service request (Network Resource Interconnection or Energy Resource Interconnection);
- Location of the proposed facility;

- Maximum MW electrical output during summer and winter seasons;<sup>15</sup>
- General description of the equipment configuration;
- Commercial operation date;
- Approximate location of the proposed Point of Interconnection (POI) (optional); and
- Generation facility data (Attachment A to Appendix 1 of the OATT)
  - Generator facility data
  - Data sheets for power flow and dynamic modeling.

Much of the generator facility data requested in Attachment A does not apply to inverter-based generators like PV plants. Instead relevant information regarding the inverters should be provided. In addition to (manufacturer, model name, number and version, other relevant information will be needed to conduct the studies. Refer to Section 3.2 of this document and Appendix A of the WECC Modeling Guide (which is included in the appendices to this document).

#### **3.1.1.1. Types of Interconnection Service**

There are two types of interconnection service that can be requested at the onset of a large generator interconnection procedure: Energy Resource Interconnection Service or Network Resource Interconnection Service. The choice of interconnection service may affect the assumptions under which the proposed project will be studied and required interconnection upgrades. Energy Resource Interconnection Service assumes that the proposed project will deliver its energy using the existing transmission system on an “as available” basis. Network Resource Interconnection Service roughly implies that the interconnection studies will determine network upgrades to allow for delivery of energy to the Transmission Provider’s network.

#### **3.1.2. Interconnection Study Stages and Their Scope**

The LGIP defines three study stages: the Interconnection Feasibility Study, the Interconnection System Impact Study, and the Interconnection Facilities Study. Each of these studies comes with its own study agreement, study assumptions, and procedures.

##### **3.1.2.1. Feasibility Study**

The Feasibility Study Agreement is contained in Appendix 2 of the LGIP and must be signed and provided to the transmission provider along with a deposit for the performance of the study. After completion of the study, the difference between the deposit and the actual cost incurred will be paid by or refunded to the interconnection customer.

The purpose of the Interconnection Feasibility Study is to identify any circuit breaker short circuit capability limits that may be exceeded as a result of the proposed interconnection, identify

---

<sup>15</sup> This is specific for conventional generators due to weather differences and cooling efficiencies between summer and winter. PV is different in that the max output is defined by the inverter MVA rating.

any thermal overload or voltage limit violations caused by the interconnection, and identify and estimate the cost of any facilities required to interconnect the proposed generation. Technically, the study consists of a power flow and a short circuit study. Before the studies begin, the interconnection customer must provide a designated POI and configuration to be studied as well as alternative POIs and configuration(s) as requested in Attachment A of LGIP's Appendix 2.

### **3.1.2.2. System Impact Study**

The SIS Agreement is contained in Appendix 3 of the LGIP and must be signed and returned to the transmission provider along with a deposit. The LGIP also requires that the interconnection customer demonstrate control of the proposed site before proceeding with the SIS.

The purpose of the SIS is to evaluate the impact to the reliability of the transmission system after the interconnection of the proposed facility. The study consists of a short circuit analysis, stability analysis, and a power flow analysis. The interconnection customer must provide a designated POI and configuration to be studied along with alternative(s) POIs and configuration if these have changed from the Feasibility Study.

Before the execution of the SIS Agreement, modifications to the interconnection request are permitted under certain instances without impacting the proposed project's position on the queue. Per Section 4.4.1 of the LGIP, modifications allowed are:

- A decrease of up 60% of electrical output;
- Modifying technical parameters of the generating facility technology or the step-up transformer impedance; and
- Modifying the interconnection configuration.

Additional modifications may require an evaluation by the transmission provider to determine whether the modification is material. Any change to the POI constitutes a Material Modification.<sup>16</sup> A restudy may be required in some cases, for example, when there are significant changes in the interconnection request or in the projects that hold senior positions in the interconnection queue.

### **3.1.2.3. Facilities Study**

The Facilities Study Agreement is contained in Appendix 4 of the LGIP and must be signed and returned to the transmission provider along with the greater of \$100,000 or an estimate of the monthly cost of performing the Facilities Study.

The purpose of the Facilities Study is to specify and estimate the cost of the equipment, engineering, and construction work needed to interconnect the proposed facility. The study will also identify electrical configurations of the transformer(s), switchgear, meters, and other station

---

<sup>16</sup> A Material Modification as defined by the LGIP is a modification that has a material impact on the cost or timing of any interconnection request with a later queue priority date.

equipment. Finally, the study will also identify the nature and estimated cost of any transmission network upgrades needed as a result of the interconnection.

Attachment A to Appendix 4 of the LGIP provides a customer schedule election for conducting the Facilities Study. The interconnection customer is provided with two options regarding the accuracy of the cost estimates to be provided in the Facilities Study. The options are:

1. ninety (90) calendar days with no more than a  $\pm$  20 percent cost estimate in the report, or
2. one hundred eighty (180) calendar days with no more than a  $\pm$  10 percent cost estimate.

Before the execution of the Facilities Study Agreement, modifications to the interconnection request are permitted under certain instances without affecting the queue position. Per Section 4.4.2 of the LGIP, modifications allowed at this stage are:

- An additional 15% decrease of electrical output; and
- Modifying technical parameters of the generating facility technology or the step-up transformer impedance.

Other modifications proposed before the initiation of the Facilities Study Agreement are subject to a material modification determination under the same rules set forth under the SIS Agreement.

### *3.1.3. Queuing*

The interconnection queue is essentially a first-come, first-served process that determines the order in which a interconnection customer's proposed facility will be studied. Upon receipt of a valid interconnection request, the transmission provider will assign the interconnection customer a queue position. The queue position is also important because it could determine the cost responsibility of the interconnection customer for the facilities needed to interconnect. Interconnection studies are conducted for each generator in the order in which they are filed and take into account all other interconnection requests and transmission service requests that hold senior positions in the queue.

With the number of interconnection requests growing, especially for renewables, interconnection queues in regions with Regional Transmission Organizations (RTOs) and Independent System Operators (ISOs) have become extremely backlogged. In March 2008, FERC held a technical conference and subsequently issued an order directing transmission providers to provide the status of their queues along with proposals for queue process reforms.<sup>17</sup> The FERC guidance was aimed at speeding the process of the interconnection studies by:

- Increasing staff to perform studies;
- Adopt more efficient modeling for studies; or
- Cluster interconnection requests in a single study.

---

<sup>17</sup> For more information, see <http://www.ferc.gov/media/news-releases/2008/2008-1/03-20-08-E-27.asp>.

The process of “clustering” multiple interconnection requests to evaluate the impacts to the transmission system in a single study is contained within the LGIP. Typically the transmission provider will have a “Queue Cluster Window” of no more than 180 days where all interconnection requests received within the window are studied together.

Many transmission providers are in the process of evaluating proposed reforms to the current FERC *pro forma* standards for queue process and management. Reform proposals are specific to the ISO or RTO and often include greater financial deposits or full demonstration of site control from interconnection customers to enter the queue (first-ready, first-served), interconnection studying techniques such as clustering, and tighter restrictions on suspension of interconnection status for projects.

### **3.1.3.1. Serial and Clustering Approaches<sup>18</sup>**

The serial approach to interconnection studies is the traditional style of the FERC LGIP. This is the first-come, first served approach in which interconnection requests are studied individually with the transmission system model based on the time the request was submitted and any modifications made from earlier interconnection requests.

The clustering approach is one that many transmission providers are moving towards. In a clustering approach, transmission providers have a window of opportunity during which interconnection requests are accepted (typically this happens twice a year). Upon the closure of the window, all valid interconnection requests are studied simultaneously. The benefit of doing this is that the interconnection studies are done for multiple projects at once. Network upgrade costs for a cluster are often shared among the interconnection projects in the cluster.

### **3.1.3.2. Queue Reform**

As a consequence of the time sensitive governmental incentives described for renewable energy described above, there has been a charge to submit interconnection requests in order to secure interconnection rights for access to transmission. That charge has created a severe backlog of interconnection requests in many areas across the nation. The FERC has taken notice of the backlog issue and has directed RTOs and ISOs to report on the status of their efforts to improve the processing of their interconnection queues.

RTOs and ISOs have identified the two biggest problems with the original interconnection requirements as the ease of entry into the interconnection queues and the serial study approach. Many transmission providers are increasing the deposit amount to enter the queue as well as requiring the applicant to meet certain milestones such as power contracts, permit acquisitions, and transmission service security deposits in order to secure a position within the queue. Transmission providers are also opting to move to the clustering approach for interconnection studies and are tightening their requirements for allowing generating projects to suspend their interconnection requests.

---

<sup>18</sup> For more information on queuing, see Section 4 of the FERC LGIP, <http://www.ferc.gov/industries/electric/indus-act/gi/stnd-gen.asp>.

Interconnection queues and study processes vary from region to region. Below are some of the reforms the various RTOs and ISOs have taken to improve the process:<sup>19</sup>

- California ISO (CAISO), Midwest Independent Transmission System Operator (MISO), New York ISO (NYISO), and PJM have moved from a serial approach to a cluster or group study approach;
- MISO, Southwest Power Pool (SPP) and NYISO have moved from a first-come, first-served approach to a first-ready, first-served approach; and
- ISO-NE has increased the deposit levels throughout the interconnection process.

### 3.2. Project Data and Modeling Requirements

The interconnection study process entails a fair amount of simulation and analysis to determine the impact of the proposed project and identify mitigation alternatives. Traditionally, three types of analysis are conducted to study the performance of the bulk power system. They are (1) short circuit, (2) steady-state power flow, and (3) dynamic transient stability. In these studies, the proposed project is represented along with the rest of the transmission system and its respective generators, loads, transformers, and other electrical equipment. Models and other project data must be provided in a format that transmission providers can incorporate in their simulation platforms. While there are many power flow and dynamic simulation tools available, most transmission providers in the United States use General Electric's PSLF and Siemen's PSSE programs for power flow and dynamic simulations.

To date there has been a lot of work understanding the data requirements for wind generators on the system but little for PV system. Recently, the Renewable Energy Modeling Task Force (REMTF) of the Western Electricity Coordinating Council (WECC) expanded its scope to address the modeling issues of PV systems.<sup>20</sup> A good resource for PV system modeling an REMTF's document titled *WECC Guide for Representation of Photovoltaic Systems in Large-Scale Load Flow Simulations*<sup>21</sup> (WECC Guide).

#### 3.2.1. Load Flow Data

Large central PV systems have a complex internal configuration and it is not practical or necessary to represent each of the components in the context of interconnection studies. The WECC Guide recommends that large-scale PV systems be modeled as a single machine equivalent, as illustrated in Figure 9.

---

<sup>19</sup> 2010 ISO/RTO Metrics Report, December 6, 2010. FERC Docket AD10-5-000.

<sup>20</sup> The REMTF, formerly known as the Wind Generation Modeling Group, is currently addressing both wind and solar generation modeling issues for the WECC.

<http://www.wecc.biz/committees/StandingCommittees/PCC/TSS/MVWG/REMTF/default.aspx>.

<sup>21</sup> *WECC Guide for Representation of Photovoltaic Systems in Large-Scale Load Flow Simulations*, <http://www.wecc.biz/committees/StandingCommittees/PCC/TSS/MVWG/REMTF/Solar%20Documents/WECC%20PV%20Plant%20Power%20Flow%20Modeling%20Guidelines%20-%20August%202010.pdf>.



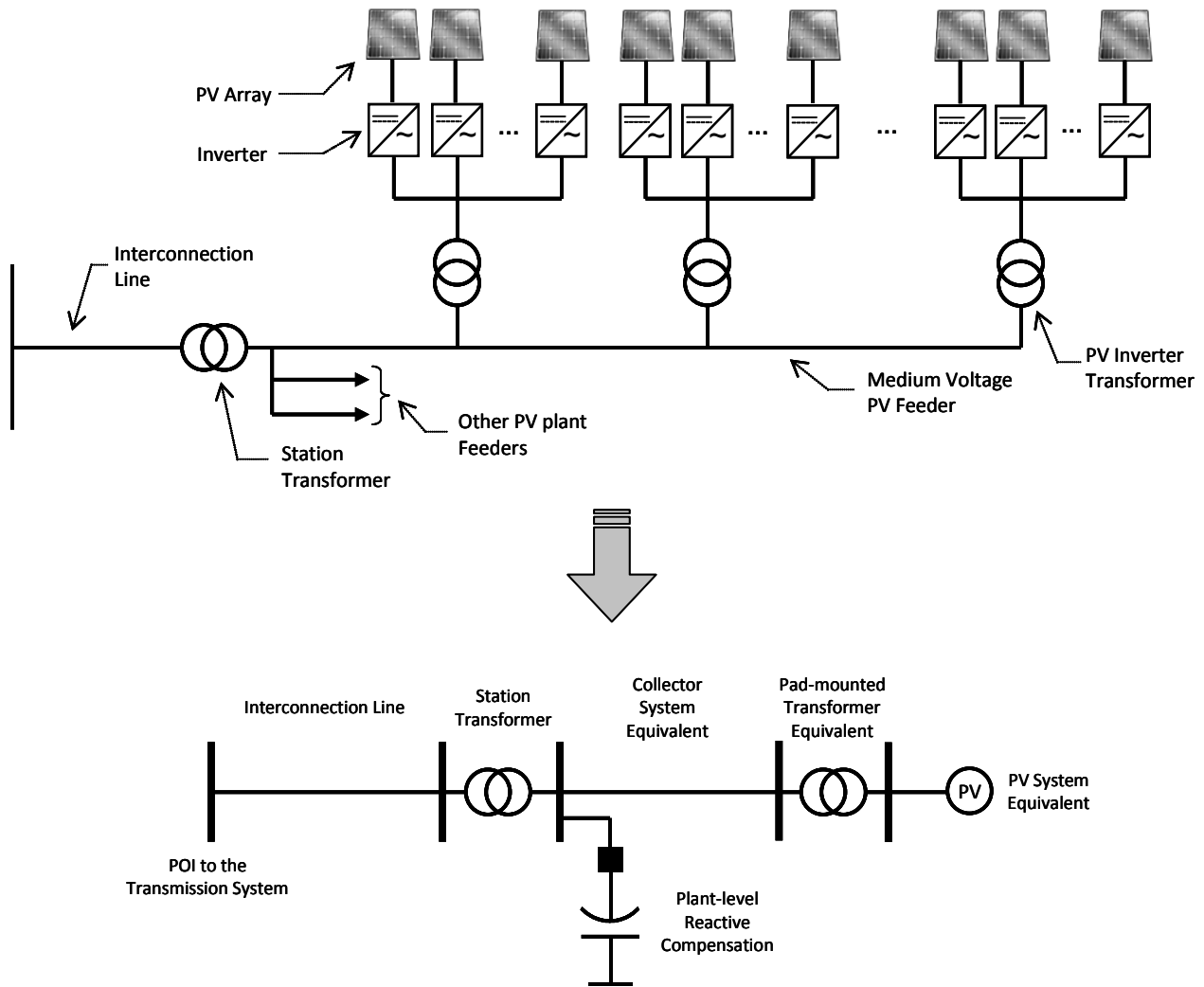

Figure 9. Generic PV plant topology and corresponding single-machine equivalent.

Quoting from the WECC Guide,

*“In this model, the equivalent generator represents the total generating capacity of all the inverters, the equivalent pad-mounted transformer represents the aggregate effect of all step-up transformers, and the equivalent collector system branch represents the aggregate effect of the PV plant collector system. With the proper model parameters, this model should approximate PV plant load flow characteristics at the interconnection point, collector system real and reactive losses and voltage profile at the terminals of the “average” inverter in the PV plant.”*

An important observation is that data requirements listed in the *pro forma* LGIP and LGIA were intended for conventional generators. A different set of data is needed for PV systems. Appendix A of the WECC Guide contains a sample PV plant data request that is more adequate for power flow representation of PV plants. It is recommended that this type of information be used to supplement the data request in the *pro forma* LGIP.

### 3.2.2. Dynamics Data

The power system is dynamic system and, as such, the full spectrum of possible behaviors cannot be predicted with a steady-state, static model. Dynamic issues within the power system, such as transient stability of rotating machines (generators and motors), are addressed using transient stability programs that examine the system from tens of milliseconds up to several seconds after an event. These programs require dynamic models of the synchronous machines, turbines and governors, loads, high-voltage direct current (HVDC) transmission lines, static var compensators (SVCs), inverters, and other fast-acting devices.

Access to dynamic models for PV (and wind) generators has been an issue for the industry.<sup>22</sup> Manufacturer-specific, user-written, and often proprietary models are often used for interconnection studies because standard models do not yet exist or are not adequate. The effort required to work with such models is significant, and can impact study cost and time significantly. In addition, such models may not be adequate to meet NERC modeling requirements for regional planning.<sup>23</sup> REMTF is currently working to improve standardized dynamic models for PV (and wind) generation.

---

<sup>22</sup> A. Ellis, M. Behnke, and C. Barker, "PV System Modeling for Grid Planning Studies," Presented at *IEEE PVSC Meeting*, Seattle, Washington, 2011.

<sup>23</sup> NERC IVGTF Task 1.1 Report, Standard Models for Variable Generation, [http://www.nerc.com/docs/pc/ivgtf/Task1-1\\_Final\\_PP022310\\_Planning.pdf](http://www.nerc.com/docs/pc/ivgtf/Task1-1_Final_PP022310_Planning.pdf).

## 4. PLANT PERFORMANCE REQUIREMENTS FOR INTERCONNECTION

Existing requirements have for the most part been centered on conventional utility-scale generation plants such as thermal (coal, natural gas, nuclear) and hydro units. Given the growing number of renewable energy generation facilities, a current challenge for the industry is to determine what expectation should be placed on these plants to reliably operate the grid.

Existing and proposed performance requirements potentially applicable to large-scale PV plants are contained in the following key documents:

- FERC LGIA – Standard Large Generator Interconnection Agreement. Article 9 deals with Operational Requirements. Explicitly there is no mention of PV in the FERC LGIA; however, a term commonly used in FERC documentation is “best utility practice,” referencing PV plants to the LGIA requirements is a reflection of that statement.
- FERC Order 661A – Specifies the technical standards applicable to a wind generating plant greater than 20 MW. Requirements refer to Low-Voltage Ride-Through, Power Factor Control, and SCADA systems. Although specifically only mentioning wind farms, many utilities are referring to FERC Order 661A for PV requirements as well.
- NERC PRC-024-1 – This proposed NERC standard provides further guidance on voltage and frequency tolerance for all generator technologies. If approved, this standard may be applied in lieu of FERC Order 661A as well as off-nominal frequency (ONF) ride-through requirements.
- Regional Criteria – Performance requirements specific to some Reliability Entities are sometimes applied to interconnection of solar generators. For example, Section 4.2 of WECC’s ONF Load Shedding Plan<sup>24</sup> defines frequency tolerance requirements for bulk generators.

Under NERC’s Planning and Operating Committees, the Integration of Variable Generation Task Force<sup>25</sup> (IVGTF) was formed to evaluate the barriers to integrating variable generation as well as providing recommendations. Within the IVGTF the interconnection subgroup’s objective is that procedures and standards should be enhanced to address voltage and frequency ride-through, reactive and real power control, frequency and inertial response, and must be applied in a consistent manner to all generation technologies. In 2009 the IVGTF released a report covering the characteristics of variable generation and its planning, technical, and operational impacts along with its recommendations for integrating variable resources into the bulk power system.<sup>26</sup> NERC recently released for comment a set of IVGTF recommendations on interconnection standards covering reactive power, voltage and frequency ride-through, etc.

---

<sup>24</sup> See [http://www.wecc.biz/library/Documentation Categorization Files/Policies/Off-Nominal Frequency Load Shedding Plan.pdf](http://www.wecc.biz/library/Documentation%20Categorization%20Files/Policies/Off-Nominal%20Frequency%20Load%20Shedding%20Plan.pdf).

<sup>25</sup> <http://www.nerc.com/filez/ivgtf.html>.

<sup>26</sup> [http://www.nerc.com/docs/pc/ivgtf/IVGTF\\_Report\\_041609.pdf](http://www.nerc.com/docs/pc/ivgtf/IVGTF_Report_041609.pdf).

## 4.1. Voltage and Frequency Tolerance

LVRT, also referred to as Fault Ride-Through (FRT), requires that the generator remain connected to the grid following a voltage disturbance. The basis for the requirement is that during a fault on the system, the immediate disconnection of a large facility would be counterproductive. LVRT requirements are a relatively new to the PV industry. PV generation initially became prominent as a form of distributed generation (DG), for which the applicable interconnection requirements are defined in the IEEE 1547 standard. According to IEEE 1547, distributed generators are required to disconnect from the grid within a certain period of time following a disturbance. The emphasis is on disconnecting from the grid to avoid interfering with protection schemes and prevent unintentional islanding.

In the United States, LVRT requirements for wind plants were first standardized in FERC Order 661A. This requirement is often applied to transmission-connected PV plants even though the standard states that it applies only to wind plants. FERC's LVRT requirement mandates that a generator shall withstand zero voltage at the POI (typically the primary side of the station transformer) for up to 0.15 seconds (9 cycles) and the ensuing voltage recovery period. The FERC requirement is not specific about the requirement for ride-through during the voltage recovery period.

NERC's proposed PRC-024-1 standard addresses voltage tolerance for all generators. If approved, NERC's voltage ride-through (VRT) standard will have to be reconciled with FERC Order 661A and other LVRT regional standards that may exist. Figure 10 shows the VRT curve contained in the proposed NERC PRC-024-1 requirement.

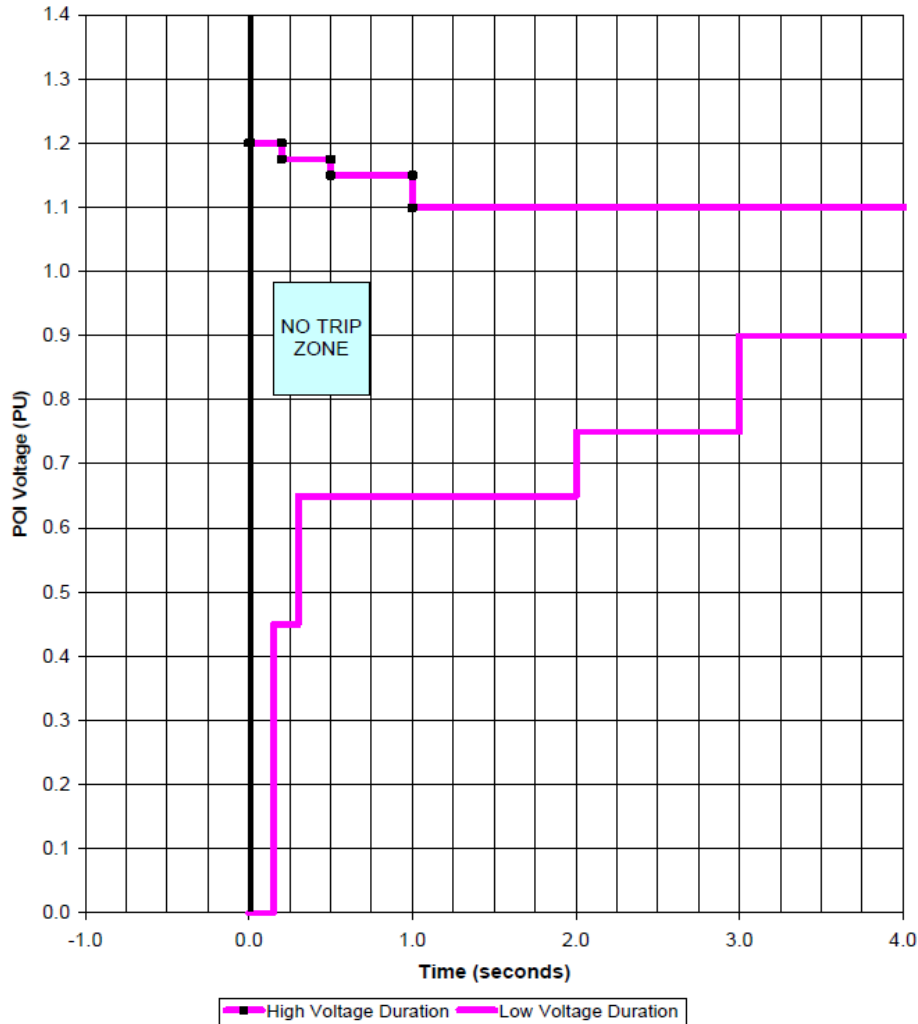

Figure 10. Proposed NERC PRC-024-1 VRT curve.

## 4.2. Frequency Tolerance (Under/Over-Frequency)

Where voltage deviations tend to be more localized, frequency deviations will effect an entire interconnection. Generator frequency tolerance is typically coordinated with under-frequency load shedding (UFLS) schemes.

The FERC LGIA states that proposed generators must meet ONF tolerance requirements of the applicable reliability council. For example, large-scale PV plants connected in the WECC footprint may need to comply with the existing WECC ONF requirement. The proposed NERC PRC-024-1 requirement also addresses generator frequency tolerance. The details of both the WECC ONF and proposed NERC PRC-024-1 frequency ride through requirements are shown in Figure 11 and Table 2. If the PRC standard is approved, discrepancies with regional ONF requirements would need to be reconciled.

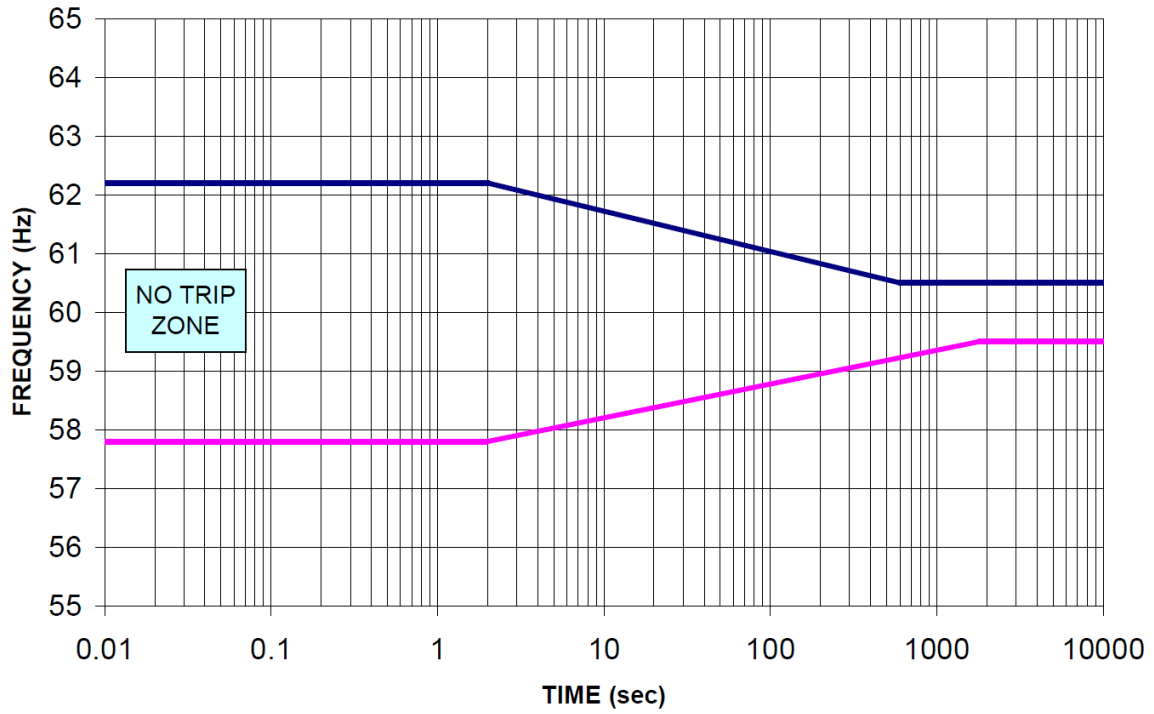

Figure 11. NERC PRC-024 and WECC frequency ride-through curves.

Table 2. WECC ONF Requirement for Generators.

WECC Frequency Ride Through Requirement		
Under-Frequency Limit	Over-Frequency Limit	Minimum Time
>59.4	60 to <60.6	N/A (continuous)
<59.4	>60.6	3 min
<58.4	>61.6	30 sec
<57.8	-	7.5 sec
<57.3	-	45 cycles
<57	>61.7	Instantaneous

### 4.3. Reactive Power Capability and Volt/VAr Control

According to the FERC LGIA, the generally accepted power factor requirement for large generators is +/- 0.95.<sup>27</sup> The '+/-' refers to leading or lagging power factor. In a conventional power plant, the reactive power range is dynamic, which means that the generator can adjust continuously within this range.

Reactive power requirements for PV plants are not well defined. Sometimes, the FERC provisions in Order 661A are applied even though the document states that it applies to wind generation only. FERC Order 661A requires that wind plants have a power factor range of +/- 0.95 measured at the POI, and provide sufficient dynamic voltage support “*if the Transmission Provider’s System Impact Study shows that such a requirement is necessary to ensure safety or reliability.*” Wind power plants are normally designed to meet the +/- 0.95 power factor range by default. For some types of wind power plants, the requirement to provide dynamic voltage support requires additional reactive power support equipment as part of the plant.

For the PV industry, provision of reactive power is a departure from the PV application in distribution systems. By default, PV inverters designed for distribution interconnection are designed to operate at unity power factor, and are unable to supply reactive power when operating at rated kW output. To maintain a +/-0.95 power factor range at nominal voltage and at rated kW output, the inverter would need to have a kVA rating at least 5.2% higher than the kW rating. Considering that inverter cost is related to the kVA (current) rating, the power factor range requirement comes at a higher cost compared to PV existing industry practice.

### 4.4. SCADA Integration Requirements

FERC Order 661A also contains Supervisory Control and Data Acquisition (SCADA) requirements for wind plants. As mentioned in the previous discussion, SCADA requirements contained in FERC Order 661A are sometimes applied to large-scale PV plants. The purpose of the requirement was for the plant owner to be able to transmit data and receive instructions from the transmission provider in order to protect system reliability. SCADA data to be shared are based on needs for real-time operations (line switching, generation dispatch, etc.), state estimation (to determine real-time stability), remedial action schemes (planned response to contingencies), and safety issues (confirming energized/de-energized components). Further details on SCADA for power system applications can be found in IEEE Standard 1547.3 (*IEEE Guide for Monitoring, Information Exchange, and Control of Distributed Resources Interconnected with Electric Power Systems*), IEC 61850 (*Standard for the Design of Electrical Substation Automation*), IEC 61400-25 (*Communications for Monitoring and Control of Wind Power Plants*), and the RUS Design Guide for Rural Substations (*Chapter 14: Substation Automation*).

---

<sup>27</sup> Reactive power capability is a function of terminal voltage. The power factor ranges quoted should be assumed to apply at nominal voltage. For additional information on this topic, please see SAND2012-1098, “*Reactive Power Interconnection Requirements for PV and Wind Plants – Recommendations to NERC*”.

## 4.5. Station Configuration and Protection

During the Feasibility Study different options for station configuration and POI for the PV generator facility are evaluated. A number of options may be feasible; however, one configuration is selected based on factors such as cost, permitting options, construction time, and system reliability. Figure 12 shows some examples of possible interconnection facility options. Other configurations are possible. In all the examples shown, it is assumed that there is an existing transmission line between Station A and Station B. Existing equipment is drawn in black, and new construction is shown in blue. For simplicity, line terminations into Stations A and B are represented by a single breaker. In reality, transmission switching stations have a more complex configuration such as a ring or breaker-and-a-half scheme.

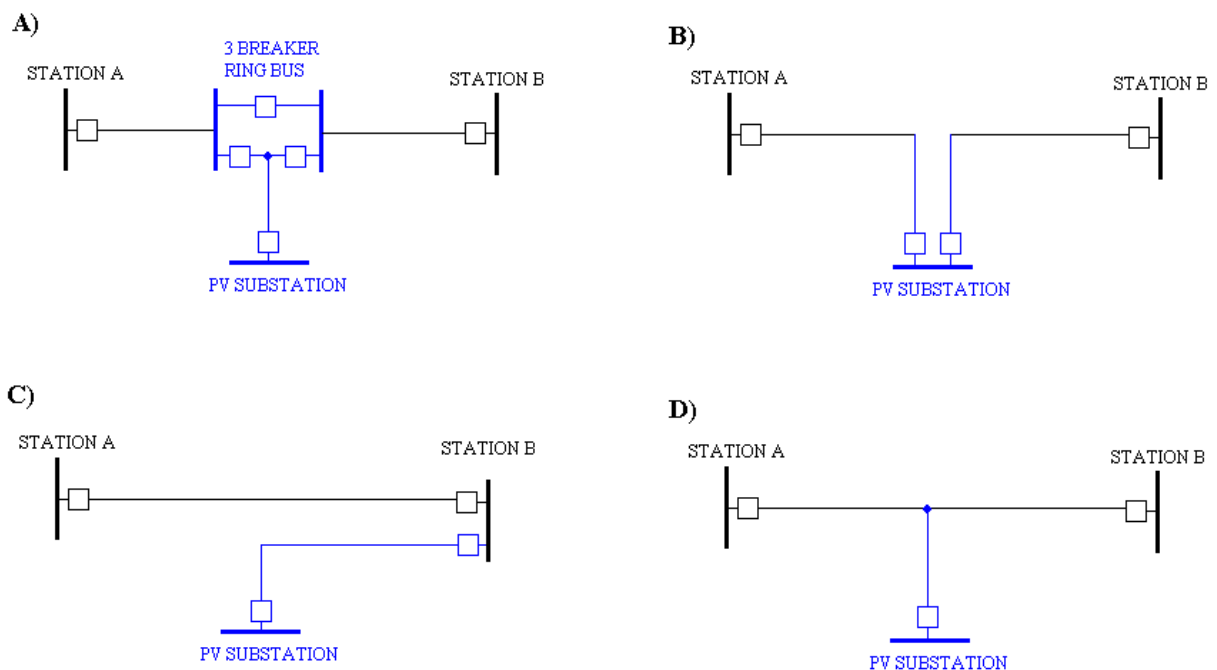

Figure 12. Examples of possible options for generator facility interconnection.

In Option A the existing transmission line is broken in order to build a new switching station with a three-breaker ring bus. The proposed PV may require a new interconnection transmission line to this new station depending on the location of the PV site. This option may allow the PV plant to operate even if the line either to Station A or to Station B is out of service. This allows for flexibility for maintenance. The tradeoff is the relatively higher cost.

In Option B the existing line is extended to the so that the new switchyard can be built next to the PV site. This configuration is similar to Option A, but could result in higher cost overall.

Option C represents a direct connection to an existing switching station. The existing Station B would have to be upgraded with additional circuit breakers and a new transmission line would be built to the PV site. One advantage of this configuration is it does not require a new transmission switching station to be developed.



Option D represents a very simple and potentially low-cost interconnection method. However, this option is often unacceptable to a utility because of reliability and operations considerations. Even if this option were considered a possibility, a more complex protection scheme would have to be implemented.

Some utilities require the installation of a synchronizing breaker for generators to avoid the use of breakers at the transmission switching stations for protection of the interconnection customer's transformer or for disconnection and reconnection of the generator.

#### **4.6. Current Efforts to Update Interconnection Procedures and Standards**

The purpose of this report is to describe in a general sense the existing requirements and procedures for interconnecting large-scale PV plants greater than 20 MW per the FERC LGIP. It should be stressed that these procedures and requirements are continuously evolving, and some of the discussion and proposed changes specifically pertain to variable generation (PV and wind). For example, California Independent System Operator Corporation (CAISO) proposed revisions to its tariff relating to interconnection requirements applicable to large asynchronous generators, predominantly wind and solar photovoltaic resources. CAISO's proposed revisions were in four specific areas: (1) power factor design and operations criteria; (2) voltage regulation and reactive power control requirements; (3) frequency and LVRT requirements; and (4) generator power management. FERC rejected the proposed changes related to reactive power design criteria, voltage regulation, and generator power management. However, FERC accepted proposed changes related to frequency and voltage ride-through, including clarification that the revised voltage and frequency ride-through standards apply to all asynchronous facilities (including PV). Specifically, CAISO's proposed revisions were summarized by the commission as follows:<sup>28</sup>

- Separate the requirements for ride-through of single-phase faults with delayed clearing from those applicable to all normally cleared faults, in order to make clear that asynchronous generators must ride through the recovery phase of single-phase faults.
- Clarify that the LVRT provisions apply to all types of normally cleared faults, not merely three-phase (i.e., two-phase or single-phase faults).
- Establish criteria to define which breaker clearing time sets the "normal" clearing time for purposes of the ride-through requirements. Specifically, the CAISO proposes that the "normal" clearing time be defined as the lesser of the maximum normal clearing time for any three-phase fault that causes the voltage at the POI to drop to or below 0.2 per unit of nominal.
- Clarify that remaining on line does not require injection of power, but requires remaining physically connected.
- Clarify that the ride-through requirement applies to the facility, but does not necessarily require each individual unit to remain connected.
- Clarify that the ride-through requirements are not applicable to multiple-fault events.

---

<sup>28</sup> See FERC Docket ER10-1706-000.

With regard to frequency ride-through, CAISO sought clarification that asynchronous generators must comply with the ONF requirements in the WECC Load Shedding Guide.

As stated earlier, NERC is working on revisions to interconnection requirements and performance standards for variable generators that will eventually need to be reconciled with FERC's ongoing proceedings. For this reason, it is recommended that stakeholders remain current with FERC and NERC proceedings.

## APPENDIX A: SAMPLE PV PLANT DATA SHEET

**1. One-Line Diagram.** This should be similar to Figure A-1.

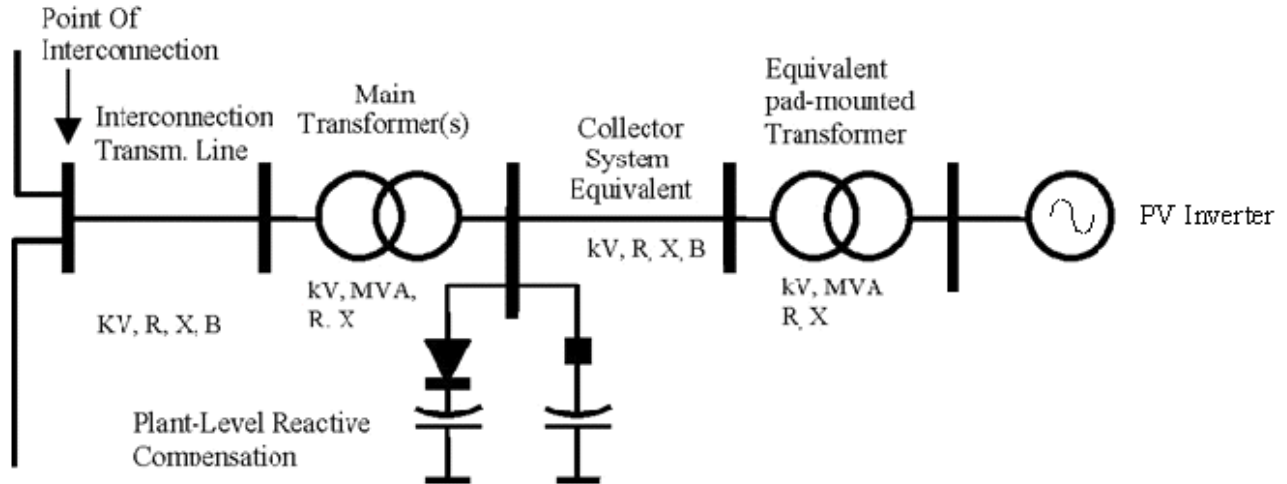

*Figure A-1. Single-machine representation one-line diagram.*

### 2. Interconnection Transmission Line.

- Point of Interconnection (substation or transmission line name): \_\_\_\_\_
- Line voltage = \_\_\_\_\_ kV
- R = \_\_\_\_\_ ohm or \_\_\_\_\_ pu on 100 MVA and line kV base (positive sequence)
- X = \_\_\_\_\_ ohm or \_\_\_\_\_ pu on 100 MVA and line kV base (positive sequence)
- B = \_\_\_\_\_  $\mu$ F or \_\_\_\_\_ pu on 100 MVA and line kV base (positive sequence)

### 3. Station Transformer.

(Note: If there are multiple transformers, data for each transformer should be provided)

- Rating (ONAN/ONAF/ONAF): \_\_\_\_\_/\_\_\_\_\_/\_\_\_\_\_ MVA
- Nominal Voltage for each winding (Low /High /Tertiary): \_\_\_\_\_/\_\_\_\_\_/\_\_\_\_\_ kV
- Available taps: \_\_\_\_\_ (indicate fixed or with LTC), Operating Tap: \_\_\_\_\_
- Positive sequence  $Z_{HL}$ : \_\_\_\_\_%, \_\_\_\_\_X/R on transformer self-cooled (ONAN) MVA

#### 4. Collector System Equivalent Model.

- Collector system voltage = \_\_\_\_\_ kV
- R = \_\_\_\_\_ ohm or \_\_\_\_\_ pu on 100 MVA and collector kV base (positive sequence)
- X = \_\_\_\_\_ ohm or \_\_\_\_\_ pu on 100 MVA and collector kV base (positive sequence)
- B = \_\_\_\_\_  $\mu$ F or \_\_\_\_\_ pu on 100 MVA and collector kV base (positive sequence)

#### 5. Inverter Step-Up Transformer.

Note: These are typically two-winding air-cooled transformers. If the proposed project contains different types or sizes of step-up transformers, please provide data for each type.

- Rating: \_\_\_\_\_ MVA
- Nominal voltage for each winding (Low/High): \_\_\_\_\_/\_\_\_\_\_ kV
- Available taps: \_\_\_\_\_ (indicate fixed or with LTC), Operating Tap: \_\_\_\_\_
- Positive sequence impedance (Z1) \_\_\_\_\_%, \_\_\_\_\_X/R on transformer self-cooled MVA

#### 6. Inverter and PV Module Data.

- Number of Inverters: \_\_\_\_\_
- Nameplate Rating (each Inverter): \_\_\_\_\_/\_\_\_\_\_ kW/kVA
- Describe reactive capability as a function of voltage: \_\_\_\_\_
- Inverter Manufacturer and Model #: \_\_\_\_\_
- PV Module Manufacturer and Model #: \_\_\_\_\_

Note: This section would also request completed PSLF or PSS/E data sheets for the generic PV library model(s) once they are available.

#### 7. Plant Reactive Power Compensation.

Provide the following information for plant-level reactive compensation, if applicable:

- Individual shunt capacitor and size of each: \_\_\_\_\_X\_\_\_\_\_ MVA
  - Dynamic reactive control device (SVC, STATCOM): \_\_\_\_\_
  - Control range \_\_\_\_\_ MVar (lead and lag)
  - Control mode (e.g., voltage, power factor, reactive power): \_\_\_\_\_
  - Regulation point \_\_\_\_\_
  - Describe the overall reactive power control strategy: \_\_\_\_\_
-

## DISTRIBUTION

### External distribution (*distributed electronically unless otherwise noted*):

- 1 American Capital Energy  
Attn: Juris Kalejs  
15 Tyngsboro Road  
North Chelmsford, MA 01863
- 2 Arizona Public Service  
Attn: Baj Agrawal  
Ronald Flood  
400 N. 5<sup>th</sup> Street, MS9674  
Phoenix, AZ 85004
- 1 California ISO  
Attn: Irena Greene  
P.O. Box 639014  
Folsom, CA 95763-9014
- 1 DOE Market Transformation (*paper*)  
Attn: Jennifer DeCesaro  
1000 Independence Ave, SW  
Washington, DC 20585
- 3 Dominion Virginia Power  
Attn: Daniel Ward  
Jim Blatchford  
Jim MacIntosh  
P.O. Box 26666  
OJRP-9  
Richmond, VA 23261
- 1 El Paso Electric  
Attn: Dennis Malone  
P.O. Box 982  
El Paso, TX 79960
- 2 EPRI  
Attn: Tom Key  
Daniel Brooks  
942 Corridor Park Blvd.  
Knoxville, TN 37932

- 1 ERCOT Austin  
Executive and Administration Center  
Attn: José Conto  
7620 Metro Center Drive  
Austin, TX 78744
- 1 First Solar  
Attn: John Bellacicco  
400 Somerset Corporate Blvd., Suite 501  
Bridgewater, NJ 08807
- 1 FPL  
Chris Wright  
700 Universe Blvd JSNJB  
Juno Beach, FL 33408-0420
- 3 Interstate Renewable Energy Council  
Attn: Michael Sheehan  
Kevin Fox  
Jason Keyes  
P.O. Box 1156  
Latham, NY 12110-1156
- 2 Lawrence Berkeley National Laboratory  
Attn: Joseph H. Eto  
Chris Marnay  
1 Cyclotron Road, MS 90-4000  
Berkeley, CA 94720
- 1 Los Angeles Department of Water and Power  
Attn: Ly Le  
1394 South Sepulveda Boulevard  
Los Angeles, CA 90025
- 2 National Grid  
Attn: James Cleary  
Robert Sheridan  
939 Southbridge St.  
Westborough, MA 01610
- 1 New Mexico State University  
Attn: Dr. Satish Ranade  
Klipsh School of ECE  
Box 3001, Dept. 3-O  
Las Cruces, NM 88003

- 2 National Renewable Energy Laboratory  
Attn: Brian Parson  
Benjamin Kroposki  
1617 Cole Blvd.  
Golden, CO 80401-3305
- 1 NRECA Cooperative Research Network  
Attn: Bob Saint  
4301 Wilson Boulevard  
Arlington, VA 22203-1860
- 1 NV Energy  
Attn: Vladimir Chadliev  
6226 West Sahara Ave.  
Las Vegas, NV 89146
- 1 Oak Ridge National Laboratory  
Attn: John Stoval  
P.O. Box 2008  
Bldg. 3147, MS-6070  
Oak Ridge, TN 37831-6070
- 1 PacifiCorp  
Attn: Jim Lacey  
825 NE Multnomah Street  
Portland, OR 97232
- 1 Power System Technologies  
Grid Advancement  
Southern California Edison  
Attn: Richard John Bravo, PE/Senior Engineer  
4799 Chestnut Street  
Westminster CA 92683
- 1 Public Service Company of New Mexico  
Attn: Jeff Mechenbier  
414 Silver Ave  
Albuquerque, NM 87102
- 2 Sacramento Municipal Utility District  
Attn: David Brown  
Mark Rawson  
P.O. 15830  
Sacramento, CA 98952-1830

- 1 San Diego GE (SEMPRA)  
Attn: Tom Bialek  
P.O. Box 129831  
San Diego, CA 92112-9831
- 1 Solar Electric Power Association  
Attn: Julia Hamm, Executive Director  
1220 19<sup>th</sup> St., Suite 401  
Washington, DC 33708
- 1 Solar Electric Power Association  
Attn: Tom Nicholas, Regional Director  
3806 Goodrich Rd.  
Valparaiso, IN 46385
- 1 Solar Energy Industries Association  
Attn: Dan Adamson  
805 15th St NW  
Washington, DC 20005-2276
- 1 Sun Edison  
Attn: Steve Voss, Director of Applied Eng.  
12500 Baltimore Ave.  
Beltsville, MD 20705
- 1 SunPower Corporation  
Attn: William Peter  
1414 Harbour Way South  
Richmond, CA 94804
- 1 Tucson Electric Power Company  
Attn: Ron Belvoir  
P.O. Box 711  
Tucson, AZ 85702-0711
- 1 U.S. Department of Energy (*paper*)  
Market Transformation – Solar Power  
Attn: Jennifer DeCesaro  
1000 Independence Ave. SW/EE-2A  
Washington, DC 20585
- 1 U.S. Department of Energy (*paper*)  
Attn: Dan T. Ton  
1000 Independence Ave. SW  
EE-2A, FORS  
Washington, DC 20585



2 U.S. Department of Energy (*paper*)  
Solar Energy Technology Program  
Attn: Kevin Lynn  
Alvin Razon  
950 L'Enfant Plaza  
Washington, DC 20585

1 U.S. Department of Energy/ALO(*paper*)  
Attn: Dan Sanchez  
Pennsylvania & H Street  
Kirtland AFB, NZ-384-3  
Albuquerque, NM 87184

1 UWIG  
Attn: Charlie Smith  
Utility Wind Integration Group  
P.O. Box 2787  
Reston, VA 20195

**Internal distribution (*distributed electronically unless otherwise noted*):**

1	MS0734	Ward I. Bower	6111
2	MS1033	Abraham Ellis	6112 ( <i>1 electronic &amp; 1 paper</i> )
1	MS1033	Charles Hanley	6112
1	MS1033	Jimmy Quiroz	6112
1	MS1108	Ross Guttromson	6113
1	MS1108	Juan Torres	6111
1	MS1124	David Minister	6124
1	MS0899	Technical Library	9536 ( <i>1 electronic</i> )





**Sandia National Laboratories**